

# SUPPLEMENT TO CATALOG AB-63 ROCKWELL-DELTA INDUSTRIAL MACHINES

THIS IS NOT A COMPLETE CATALOG



20" Drill Press



17" Variable Speed  
Drill Press



15"-6" Stroke  
Drill Press



10" Grinder



6" Tool Grinder



1/2 H.P. Long  
Shaft Buffer



Sander/Grinder



10" Bench Saw



10" Portable  
Radial Saw



12" Gap Bed  
Wood Lathe

**DISTRIBUTED BY:**

# ROCKWELL-DELTA "W-T TYPE"

# 20<sup>00</sup> DRILL PRESSES

Built for handling heavy work loads with precision accuracy, these rugged Light-Heavyweights frequently replace heavy, fixed machinery costing much more.

Delta "W-T TYPE" 20" drill presses feature massive one piece heads, strong rigid columns, full 6" travel, ten spline spindles and giant  $2\frac{3}{8}$ " diameter quills.

Five row bearing construction and wear adjustment controls plus Delta's famous precision engineering assure you of getting continuous accuracy even on a 24 hour a day, year in-year out schedule.

Big capacity (1" dia. holes in cast iron) plus an unusually wide selection of speed ranges make these 20" Light-Heavyweights ideal for use throughout every shop. Use them where you need to speed up any operation.

## SELECT FROM 56 MODELS

Hand or New Power Feed—Single or Multiple Spindle No. 2 or 3 Morse Taper—Standard or Extra-Slow Speed.

### FLOOR MODEL

Hand Feed, Production Table Model. Also available with Power Feed and in Tilting Table Models. Choice of No. 2 or No. 3 Morse Taper Spindle in standard or new extra slow speed units. Tables have ground work surfaces.

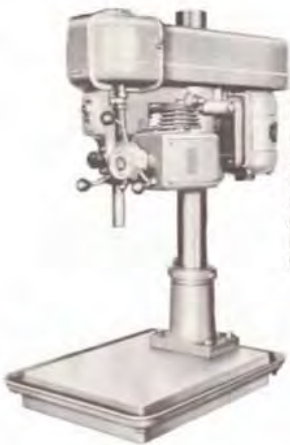

### BENCH MODELS

New power feed model illustrated. Also available in hand feed model. Choice of No. 2 or No. 3 Morse Taper spindle with or without new planetary gear spindle pulley for extra-slow drilling speeds. Complete with production table with 24" x 18" work surface.

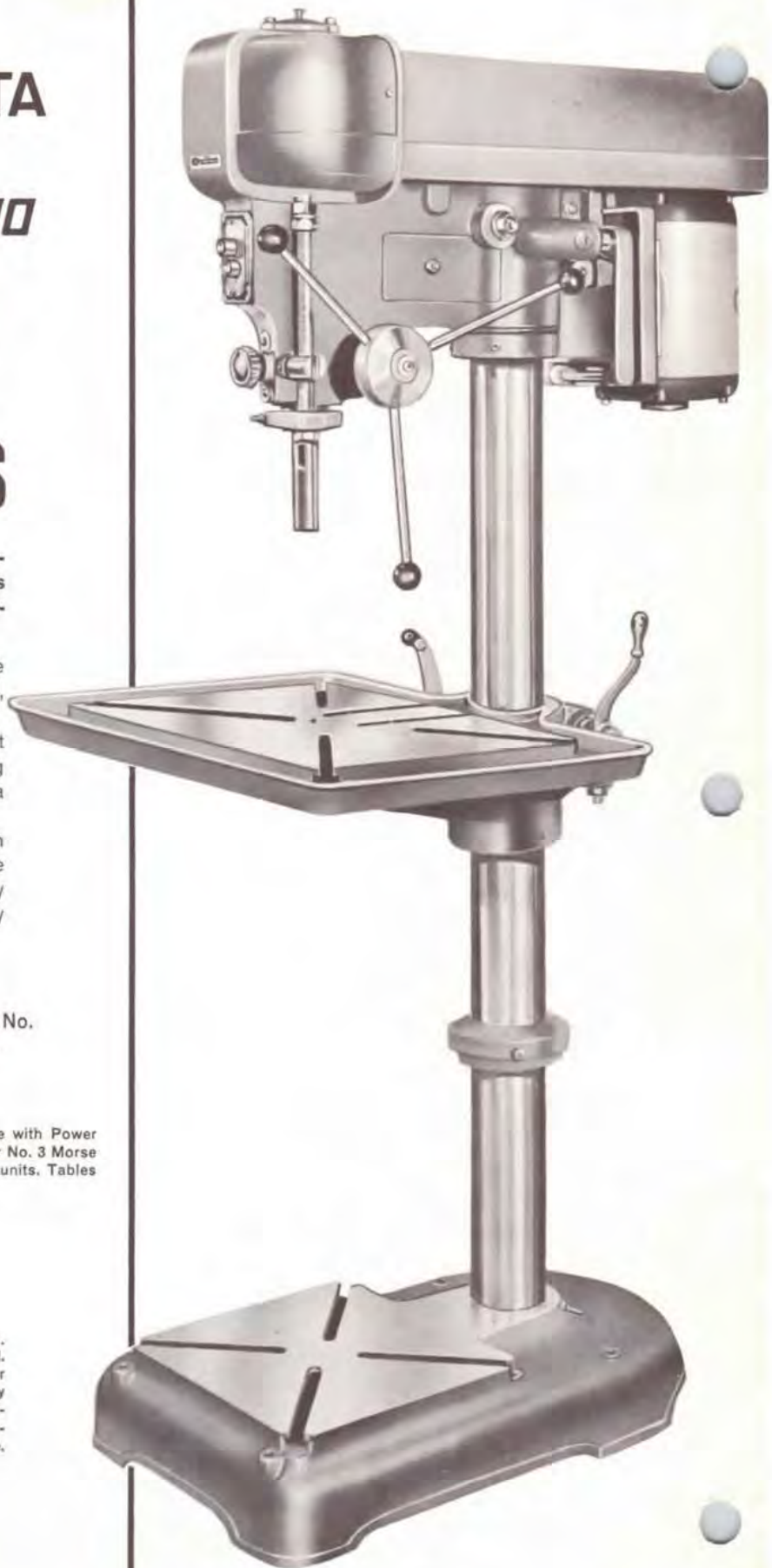

## SPECIFICATIONS

### OVERALL DIMENSIONS

Bench Type	
Height.....	54"
Width.....	23"
Front to rear.....	40"
Floor Type	
Height.....	74"
Width.....	22"
Front to rear.....	37"

### TABLE WORKING SURFACE

Production	
Ground Surface.....	15 x 18"
Ground Surface, Including Coolant Trough.....	19 1/2 x 22"
Tilting Table.....	16 x 18"

### BASE WORKING SURFACE

Bench Model.....	18 x 24"
Floor Model.....	13 1/2 x 14 1/4"

### QUILL

Stroke (Manual Feed).....	0 to 6"
Stroke (Power Feed).....	1/2 to 6"
Diameter.....	2 3/8"

### CAPACITIES

Dia. Hole in Cast Iron.....	1"
In Steel.....	3/4"

### SPINDLE SPEEDS

With Std. Spindle Pulley—All Models

W/1725 rpm motor.....	500, 800, 1200, 1800, 2600 rpm
W/1140 rpm motor.....	330, 520, 800, 1200, 1700 rpm

With Geared Spindle Pulley—Hand Feed Models

W/1725 rpm motor.....	165, 265, 400, 500, 600, 800, 1200, 1800, 2600 rpm
W/1140 rpm motor.....	110, 175, 265, 330, 395, 530, 575, 790, 1200, 1700 rpm

\*With Geared Spindle Pulley—Power Feed Models

W/1725 rpm motor.....	165, 265, 400, 500, 600, 800, 1200, 1800 rpm
W/1140 rpm motor.....	110, 175, 265, 330, 395, 530, 790, 1200 rpm

### SPINDLE FEEDS

Power Feed Models.....	.003, .006, .009, .012, .015 ipr
------------------------	----------------------------------

### FEED PRESSURE

Infinitely variable from 0 to maximum required

Column: Wall thickness.....	1/2"
Diameter.....	3 3/4"
Motor Plate.....	

Accommodates NEMA Frame Motors 182 and 184

\*Eight additional speeds may be obtained by using longer V-belt 49-109 (order separately). Range with 1725 rpm motor is 240 to 2100 rpm, and with 1140 rpm motor, 180 to 1390 rpm.

## ROCKWELL-DELTA 20" DRILL PRESSES

NOW! with Revolutionary New UP-FRONT POWER FEED and New Slo-Speed Planetary Gear Spindle Pulleys



Slo-Speed Planetary Gear Spindle Pulleys (available as an accessory)—Replace the standard spindle pulley of 20" drill presses to provide an extra-low range of spindle speeds in addition to the standard speeds available. This makes it possible to drill stainless steels, bronzes and other hard-to-drill materials, also handle reaming, tapping and similar slow speed operations. The new slo-speed planetary gear spindle pulleys multiply the torque and reduce the standard speeds by a 3:1 ratio. You can change from direct V-belt drive to low range gear drive—as required—by a simple turn of a key. (For further information, see page 15 in Delta AB-63 catalog).

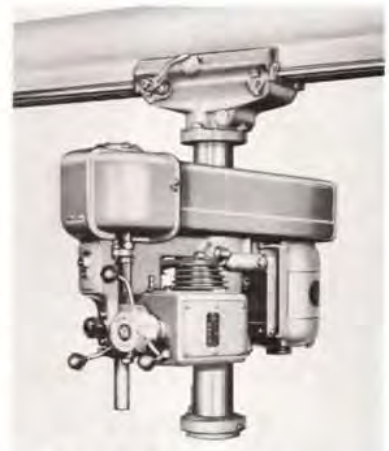

**UP-FRONT POWER FEED** (available as an accessory)—Delta 20" Drill Press Power Feed Models are now equipped with a totally new type of power feed that features a unique front-mounted pilot wheel control to permit one hand engagement for production drilling operations. (For further information, see page 14 in Delta AB-63 catalog).

### MULTIPLE SPINDLE MODELS

Choice of any number of spindles, hand or power feed, standard or extra-slow speed, No. 2 or No. 3 Morse Taper Spindle. Complete with production table.

Multiple Spindle Models may be ordered as units or as component parts for arrangement to meet your exact requirements. Legs are included as standard equipment.

### DRILL HEADS FOR OVERHEAD MODELS AND FOR SPECIAL SETUPS

Using the basic Drill Head Models, the No. 20-661 Raising Mechanism and the No. 20-623 Column and Ball Bearing Carriage Assembly you can readily build a versatile overhead set-up. Mounted on a jib crane or overhead track the unit is especially practical for drilling large or heavy work or where 360° rotation is desired.

Because of their adaptability and big capacity, all drill heads can be used effectively in special set-ups to solve radial, angular, horizontal and other particular drilling problems.



ROCKWELL-DELTA "W-T TYPE"  
20" DRILL PRESSES PROVIDE  
THESE IMPORTANT PRODUCTION  
**FEATURES**

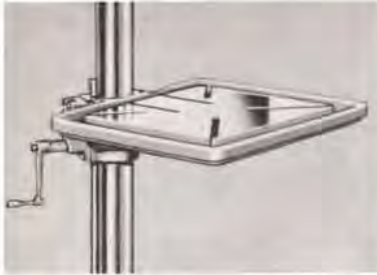

**BIG PRODUCTION TABLE**—Extra large table with 19 $\frac{1}{4}$ " x 22" work surface has diagonal and parallel blind T-slots to facilitate clamping of jig and fixtures.

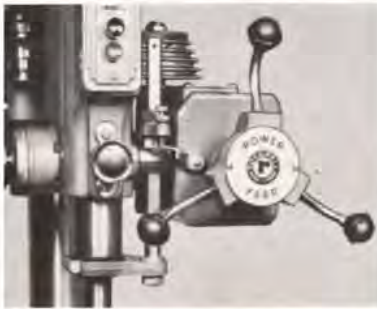

**UP-FRONT CONTROLS**—Safety designed "on-off" switch (accessory), large quill lock knob, and easy-to-read depth stop and depth indicator gauges are all conveniently located "up-front" for easier, faster and safer operation.

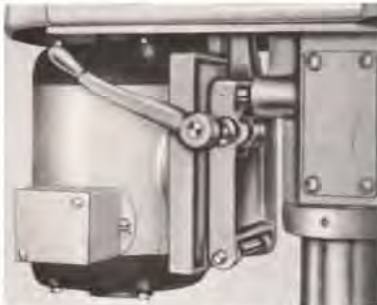

**QUICK RELEASE MOTOR MOUNT**—Single lever control operates pivoting cam-actuated motor mount to permit easy speed changes. Assures proper belt tension at all speeds for longer belt life. Five standard spindle speeds available—depending on motor rpm.



**EXTRA SLOW DRILLING SPEEDS**—New planetary gear spindle pulley models provide extra-low range of gear drive speeds in addition to standard direct drive speeds for drilling stainless steels, bronzes and other hard-to-drill materials.

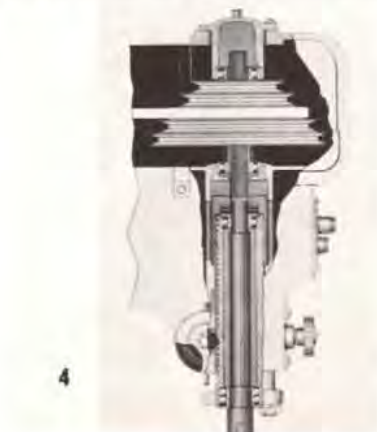

**RUGGED PRECISION SPINDLE CONSTRUCTION**—Five rows of bearings, including a double row close to work load, assure accuracy. Big ten-spline manganese steel spindle and 2 $\frac{3}{4}$ " diameter quill provide extra ruggedness. Bearings support pulley independent of spindle, eliminating transmission of belt pull to spindle.

DELTA "W-T TYPE" 20" DRILL PRESS  
**COMPONENTS**

FOR SPECIAL SET-UPS AND APPLICATIONS . . . FOR  
EXTRA DRILLING VERSATILITY

Drill Heads only may be purchased (see single spindle model listing) and built up with these Delta components for special-purpose drilling applications. Use them to solve special production drilling problems.

**DATA SHEETS ARE AVAILABLE TO AID IN SPECIAL MACHINE DESIGN COLUMNS**

Column, steel, 3 $\frac{3}{4}$  x 33", with  $\frac{1}{2}$ " wall. 50 lbs. **No. 20-625**  
Column, steel, 3 $\frac{3}{4}$  x 42", with  $\frac{1}{2}$ " wall. 55 lbs. **No. 20-626**  
Column, steel, 3 $\frac{3}{4}$  x 66", with  $\frac{1}{2}$ " wall. 102 lbs. **No. 20-627**  
Column, steel, 3 $\frac{3}{4}$  x 78", with  $\frac{1}{2}$ " wall. 128 lbs. **No. 20-628**  
Flange, with screws, for mounting column on table (not for single spindle floor models). **No. 20-624**

Ball Bearing Carriage with 33" column for Overhead Drill Press. **No. 20-623**  
**RAISING MECHANISM**  
Raising Mechanism for head or table of 20" Drill Press. Includes ball bearing thrust collar, rack, gear assembly and crank. **No. 20-661**

**TABLES**  
Production Table, ground work surface 24" front to back by 18" wide, for single spindle bench model. Does not fit 50-399 Legs. **No. 20-651**  
Production Table, one-piece, for two spindle setup. Drilled and tapped for column mounting flanges on 17 $\frac{1}{2}$ " centers. Ground work surface 24 $\frac{1}{2}$ " x 35 $\frac{1}{2}$ ". Fits 50-399 Legs. **No. 20-652**

Production Table, one-piece, for three spindle setup. Drilled and tapped for column mounting flanges on 26 $\frac{1}{4}$ " centers. Machined work surface 24 $\frac{1}{2}$ " x 70 $\frac{1}{2}$ ". Fits 50-399 Legs. **No. 20-653**

Production Table, one-piece, for four spindle setup. Drilled and tapped for column mounting flanges on 17 $\frac{1}{2}$ " centers. Machined work surface 24 $\frac{1}{2}$ " x 70 $\frac{1}{2}$ ". Fits 50-399 Legs. **No. 20-654**

Production Table, two-piece, for six spindle setup. Drilled and tapped for column mounting flanges on 17 $\frac{1}{2}$ " centers. Machined work surface 24 $\frac{1}{2}$ " x 105 $\frac{1}{2}$ ". Fits 50-399 and 50-506 Legs. **No. 20-656**

Production Table, right end section, drilled and tapped for two columns on 17 $\frac{1}{2}$ " centers, 25" x 35 $\frac{1}{4}$ " ground work surface. **No. 20-657**

Production Table, left end section, drilled and tapped for two columns on 17 $\frac{1}{2}$ " centers, 25" x 35 $\frac{1}{4}$ " ground work surface. **No. 20-658**

Production Table, center section, drilled and tapped for two columns on 17 $\frac{1}{2}$ " centers, 25" x 35" ground work surface. **No. 20-659**

**LEGS**  
Legs, steel, one pair 27 $\frac{1}{2}$ " high. For mounting production tables 20-652, 20-653, 20-654 and 20-656. **No. 50-399**

Leg, steel, 27 $\frac{1}{2}$ " high. For mounting production tables. Cannot be used with table 20-651. **No. 50-506**

Riser Blocks, cast iron, one pair, 2" high with studs, nuts and lock washers for mounting under Legs 50-399 and 50-506. **No. 50-400**

One pair required for each single leg to raise machine 2". Two blocks can be stacked to raise machine 4".  
Floor Rest. Recommended for multiple spindle production models especially with four or more spindles or where heavy work pieces may cause table sag. Consists of 2 $\frac{3}{4}$ " steel column, base with holes for lagging to floor and V-pad for supporting rib of table. Screw type jack feature permits height of pad to be adjusted from 27 $\frac{1}{2}$ " to 29 $\frac{1}{2}$ ". 20 lbs. **No. 50-401**

Note: Minimum center to center distances for columns are:  
Hand Feed Models—13"; Power Feed Models—16".

**DO MANY ADDITIONAL JOBS WITH THESE DELTA ACCESSORIES**

**RAISING MECHANISM**  
Raising Mechanism for head or table of 20" Drill Press. Includes ball bearing thrust collar, rack, gear assembly and crank. **No. 20-661**

**TABLES**  
Tilting Table, ground work surface 16" front to back by 18" left to right, slotted, with column bracket and tilt angle scale. Tilts 90° left and right and has index pin for level position. Left side has 4 x 16" ground, vertical work clamping surface. Without 20-661 Raising Mechanism. For single spindle floor model drill presses. **No. 20-660**

Production Table, 15" x 18" ground work surface (including coolant trough, 19 $\frac{1}{4}$  x 22"), with 4 diagonal and 2 parallel blind T slots for  $\frac{1}{2}$ " bolts. Without 20-661 Raising Mechanism. For single spindle floor model drill presses. **No. 20-650**

**MORTISING ATTACHMENT**  
Use with 968 Drill Chuck in 20" Drill Presses with No. 2 M.T. spindle only. Includes fence with mounting bolts, two hooked rods, adjustable hold-down and chisel holder. 16 lbs. **No. 20-640**

**DRILL CHUCK**  
3-jaw type, 0- $\frac{1}{2}$ " capacity, with No. 3 M.T. shank. Includes chuck key. Use with straight shank drills in a drill press with No. 3 M.T. spindle. 3 lbs. **No. 17-820**

**QUILL ASSEMBLIES**  
Used to change any No. 3 M.T. spindle model to No. 2 M.T. spindle. Consists of quill with No. 2 M.T. spindle, assembled with collar, ball bearings and flinger collar. **No. 20-420**

Used to change any No. 2 M.T. spindle model to No. 3 M.T. spindle. Consists of quill with No. 3 M.T. spindle, assembled with collar, ball bearings and flinger collar. **No. 20-430**

**MOTOR PULLEY**  
5-step. Specify  $\frac{1}{8}$ ",  $\frac{3}{16}$ ",  $\frac{1}{4}$ " or 1" bore. 3 $\frac{1}{2}$  lbs. **No. 49-235**



**V-BELTS**  
Standard (steel reinforced), 62 $\frac{13}{32}$ " O.C.  $\frac{3}{4}$  lb. **No. 49-108**  
Upper, for Power Feed, 29" O.C.  $\frac{1}{2}$  lb. **No. 49-101**  
Lower, for Power Feed, 23 $\frac{15}{16}$ " O.C.  $\frac{1}{2}$  lb. **No. 49-123**

# CATALOG LISTING

## ROCKWELL-DELTA "W-T TYPE" 20" DRILL PRESSES

SINGLE SPINDLE MODELS	Type of Feed, Spindle and Speed							
	Hand Feed				Power Feed			
	No. 2 Morse Taper		No. 3 Morse Taper		No. 2 Morse Taper		No. 3 Morse Taper	
	Standard Speed	Extra Slow Speed	Standard Speed	Extra Slow Speed	Standard Speed	Extra Slow Speed	Standard Speed	Extra Slow Speed
<b>Bench Model</b> (with production table— 24" x 18" work surface)	70-401 Wt. 422 lbs.	70-441 Wt. 422 lbs.	70-411 Wt. 422 lbs.	70-451 Wt. 422 lbs.	70-521 Wt. 450 lbs.	70-541 Wt. 450 lbs.	70-531 Wt. 450 lbs.	70-551 Wt. 450 lbs.
<b>Floor Model</b> (with production table— 19¼" x 22" work surface)	70-407 Wt. 460 lbs.	70-447 Wt. 473 lbs.	70-417 Wt. 460 lbs.	70-457 Wt. 473 lbs.	70-527 Wt. 500 lbs.	70-547 Wt. 500 lbs.	70-537 Wt. 500 lbs.	70-557 Wt. 500 lbs.
<b>Floor Model</b> (with tilting table—16" x 18" work surface; tilts 90° r. & l.)	70-408 Wt. 464 lbs.	70-448 Wt. 464 lbs.	70-418 Wt. 464 lbs.	70-458 Wt. 464 lbs.	70-528 Wt. 500 lbs.	70-548 Wt. 500 lbs.	70-538 Wt. 500 lbs.	70-558 Wt. 500 lbs.
<b>Drill Heads</b> (less No. 20-661 raising mechanism)	70-400 Wt. 180 lbs.	70-440 Wt. 180 lbs.	70-410 Wt. 180 lbs.	70-450 Wt. 180 lbs.	70-520 Wt. 200 lbs.	70-540 Wt. 200 lbs.	70-530 Wt. 200 lbs.	70-550 Wt. 200 lbs.

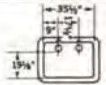
Production tables have 1/8" coolant trough with two 3/4" pipe taps at rear.

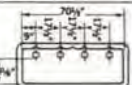
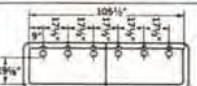
MULTIPLE SPINDLE MODELS No. of Spindles Type of Table	Type of Feed, Spindle and Speed							
	Hand Feed				Power Feed			
	No. 2 Morse Taper		No. 3 Morse Taper		No. 2 Morse Taper		No. 3 Morse Taper	
	Standard Speed	Extra Slow Speed	Standard Speed	Extra Slow Speed	Standard Speed	Extra Slow Speed	Standard Speed	Extra Slow Speed
<b>2-Spindle</b> <b>One-piece table</b> 	70-402 Wt. 969 lbs.	70-442 Wt. 981 lbs.	70-412 Wt. 969 lbs.	70-452 Wt. 981 lbs.	70-522 Wt. 1059 lbs.	70-542 Wt. 1071 lbs.	70-532 Wt. 1059 lbs.	70-552 Wt. 1071 lbs.
<b>3-Spindle</b> <b>One-piece table</b> 	70-403 Wt. 1575 lbs.	70-443 Wt. 1593 lbs.	70-413 Wt. 1575 lbs.	70-453 Wt. 1593 lbs.	70-523 Wt. 1650 lbs.	70-543 Wt. 1668 lbs.	70-533 Wt. 1650 lbs.	70-553 Wt. 1668 lbs.
<b>4-Spindle</b> <b>One-piece table</b> 	70-404 Wt. 1808 lbs.	70-444 Wt. 1832 lbs.	70-414 Wt. 1808 lbs.	70-454 Wt. 1832 lbs.	70-524 Wt. 1808 lbs.	70-544 Wt. 1932 lbs.	70-534 Wt. 1908 lbs.	70-554 Wt. 1932 lbs.
<b>6-Spindle</b> <b>Two-piece table</b> 	70-406 Wt. 2672 lbs.	70-446 Wt. 2720 lbs.	70-416 Wt. 2672 lbs.	70-456 Wt. 2720 lbs.	70-526 Wt. 3072 lbs.	70-546 Wt. 3108 lbs.	70-536 Wt. 3068 lbs.	70-556 Wt. 3070 lbs.

The 2, 3 and 4 spindle drill presses have one-piece tables. The 6 spindle drill press has a two-piece table. Tables on multiple spindle units have 1/8" coolant trough. Table working surface is 32 1/2" from the floor. Six spindle units have three legs—all other multiple spindle units have two legs. Maximum distance spindle nose to table with No. 3 M.T.—26", with No. 2 M.T.—26 1/2".

**STANDARD EQUIPMENT**—Hand Feed Models: 49-108 V-belt, 49-235 motor pulley (3/4" bore), 20-661 raising mechanism and belt guard.

Power Feed Models: 49-108 V-belt, 49-101 V-belt, 49-123 V-belt, 49-235 motor pulley (3/4" bore), 20-661 raising mechanism and belt guard.

### MOTORS AND CONTROLS (MOUNTED)

#### FACTORY RECOMMENDED ELECTRICAL COMPONENTS:

For most drill press operations it is best to order the "first choice" electrical components indicated below. Experience has shown that the "first choice" meets most situations, at the lowest price possible in line with good drilling practice.

"First Choice" for 20" Standard Spindle Pulley Drill Presses  
 Single Phase Order basic drill press and 49-442  
 Three Phase Order basic drill press and 49-443  
 "First Choice" for 20" Geared Spindle Pulley Drill Presses  
 Single Phase Order basic drill press and 49-444  
 Three Phase Order basic drill press and 49-445

### DIMENSIONAL DATA

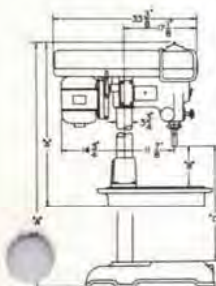

20" DRILL PRESS "W-T Type"	No. 2 Morse Taper Models			No. 3 Morse Taper Models		
	"A"	"B"	"C"	"A"	"B"	"C"
	Overall Height	Spindle To Table (max.)	Spindle To Base (max.)	Overall Height	Spindle To Table (max.)	Spindle To Base (max.)
<b>Bench Type W/Production Table</b>	55"	26 1/2"	—	55"	26"	—
<b>Floor Type W/Production Table</b>	74"	36 1/4"	45 1/4"	74"	35 3/4"	44 3/4"
<b>Floor Type W/Tilting Table</b>	74"	35 3/8"	45 1/4"	74"	34 3/8"	44 3/4"

### ELECTRICAL COMPONENTS MOUNTED AND WIRED (Motors and Push Button Switches)

	*Single Phase, Cap'r Start (Mounted, wired for 115V)	**Three Phase (Mounted, wired for 220V)
1725 RPM, 1 HP	49-444	49-445
1725 RPM, 1 1/2 HP		49-407
1140 RPM, 1 HP	49-442	49-443
1140 RPM, 1 1/2 HP		49-409

\*Includes push button switch in head and 8' cord with 3-prong grounding type plug. \*\*Includes push button manual control switch in head.

**NOTE:** Motors and motor controls for the Delta "W-T Type" 20" drill press may be ordered unmounted. For listing, see page 7 in the Delta AB-63 catalog.

ROCKWELL-DELTA

# 17<sup>00</sup> VARIABLE SPEED DRILL PRESSES

- Extra Speeds To Do More Jobs!
- Greater Efficiency for Economy!
- More Conveniences for the Operator!

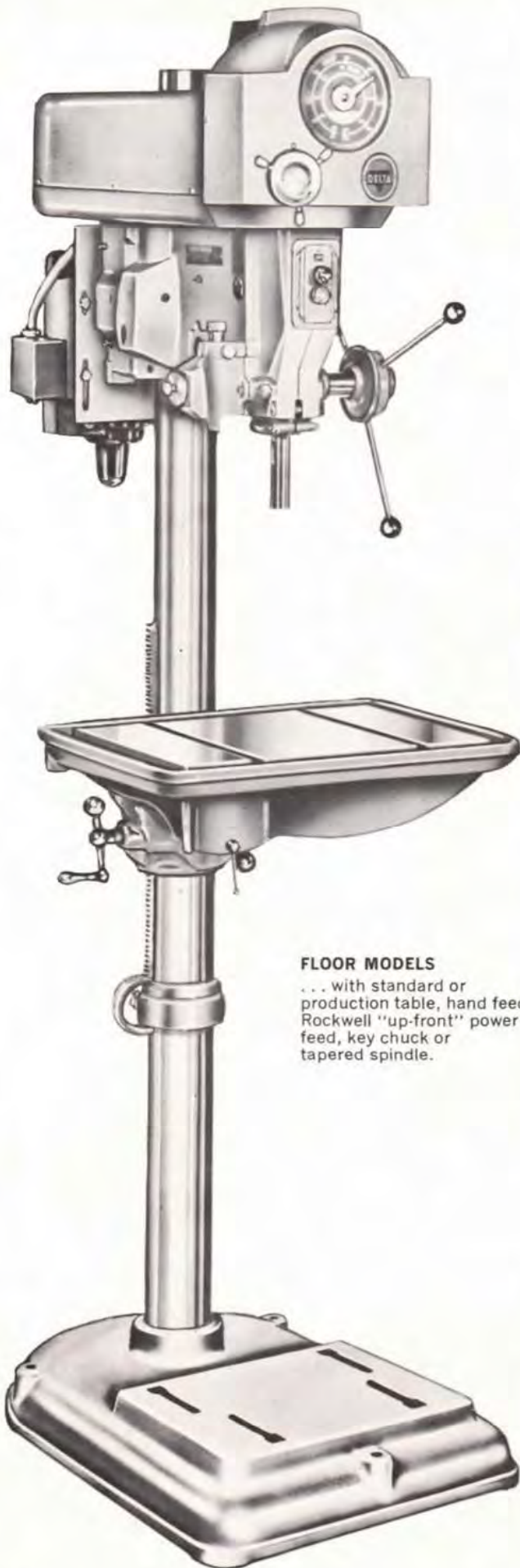

#### FLOOR MODELS

... with standard or production table, hand feed or Rockwell "up-front" power feed, key chuck or tapered spindle.

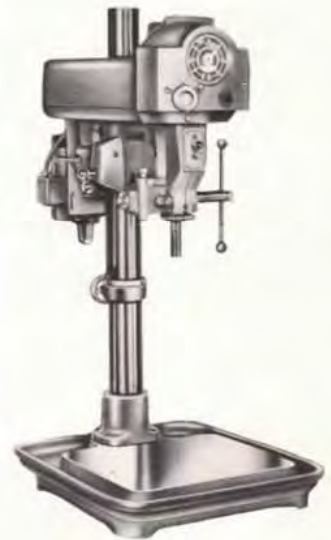
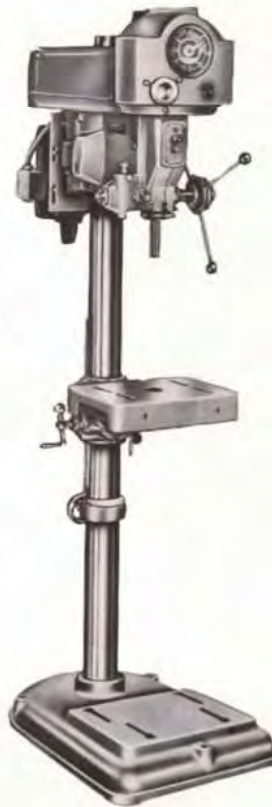

#### BENCH MODELS

... with production table, hand feed or Rockwell "up-front" power feed, key chuck or tapered spindle.

In the tool room, experimental department, machine or model shop, and in school or cabinet shops, the New Delta 17" Variable Speed Drill Press will meet your most demanding requirements.

It's the finest machine ever offered in its class. Why? Because only the Delta Variable Speed 17 provides a 12 to 1 speed ratio, enabling you to do superior work with almost any material. Only Delta offers you a variable speed drive with "Stabilizer Control," assuring perfect belt alignment and higher power transmission efficiency. Only Delta makes available a Unique Double Spindle, eliminating spindle whip and providing greater accuracy. Only Delta offers the New Concept Depth Stop that prevents quill deflection.

These and many other outstanding features make the New Delta 17" Variable Speed Drill Press perfectly suited for many operations. It will capably handle many of the production jobs ordinarily done by heavy, fixed, expensive machines. It can be moved in and out of the line to relieve production bottlenecks. Even more important, it offers the job versatility required by many users in today's competitive markets.

Let us demonstrate this BIG PERFORMER for you today!

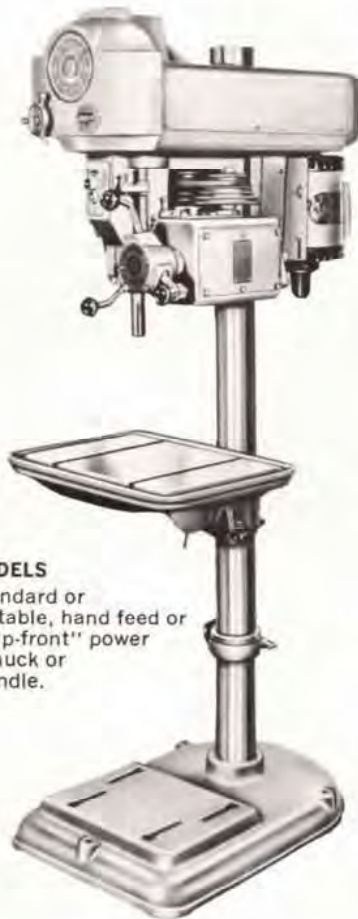

#### FLOOR MODELS

... with standard or production table, hand feed or Rockwell "up-front" power feed, key chuck or tapered spindle.

#### MACHINE DATA

##### Overall Dimensions:

Bench Type: Height.....52-7/16"  
 Width.....23 5/8" Front to Rear...36 3/8"  
 Floor Type (Production Table): Height...72 1/4"  
 Width.....20 1/2" Front to Rear...32 3/8"

##### Table Working Surface:

Standard.....11 x 12"  
 Production: Ground Surface.....12 1/2 x 17"  
 Including coolant trough.....16 x 20 1/2"

##### Base Working Surface:

Bench.....16 x 18"  
 Floor.....10 1/4 x 13 3/4"

##### Quill:

Stroke (Manual Feed).....0 to 5"  
 Power Feed.....1/2 to 5"  
 Diameter.....2 1/4"

##### Capacities:

Key Chuck.....0 to 1/2"  
 Diameter Hole in Cast Iron.....3/4"  
 In Steel.....5/8"  
 Spindle Nose to Table, Maximum:

##### Key Chuck Models:

Bench Type, Production Table...24-11/16"  
 Floor Type, Standard Table...33-3/4"  
 Floor Type, Production Table...31-15/16"  
 Multiple Spindle Machines...24-11/16"

##### No. 2 MT Models:

Bench Type, Production Table...24-11/16"  
 Floor Type, Standard Table...33-3/4"  
 Floor Type, Production Table...31-15/16"  
 Multiple Spindle Machines...24-11/16"

##### Spindle Nose to Base, Maximum:

Key Chuck Models: Floor Type...44 7/16"  
 No. 2 MT Models: Floor Type...44-7/16"

##### Spindle Speeds:

With 1725 rpm motor.....350 to 4250 rpm  
 With 1140 rpm motor.....230 to 2830 rpm

##### Power Feed Models:

Feeds... .003, .006, .009, .012, and .015 ipr  
 Feed Pressure.....Infinitely variable from  
 0 to maximum required

Column Diameter.....3 1/2"  
 Wall Thickness.....11/64"  
 Motor Plate.....Accommodates NEMA Frame  
 Motors 182 and 184



The portability of the New Delta 17" Variable Speed Drill Press permits it to be temporarily placed in a permanent multiple spindle production line to handle an extra operation on a short run part.

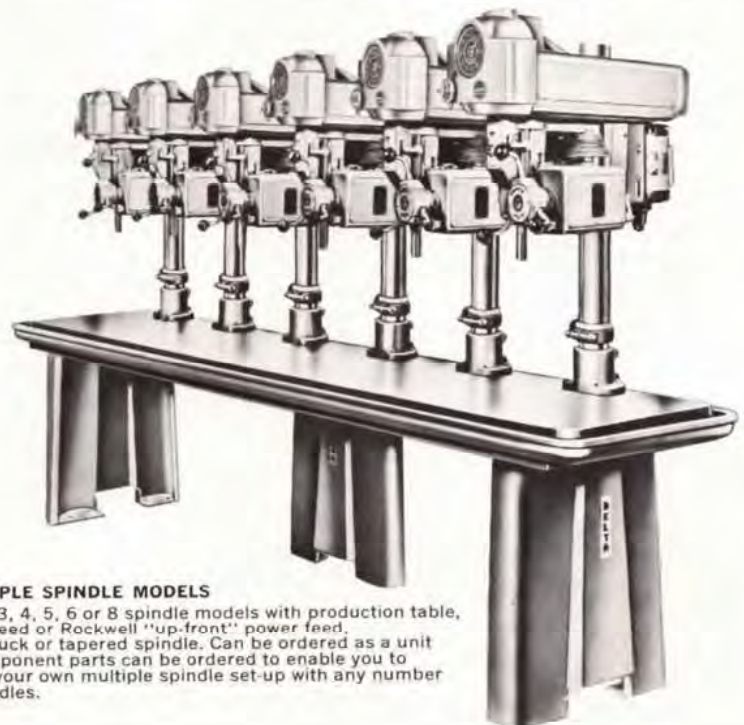

#### MULTIPLE SPINDLE MODELS

... 2, 3, 4, 5, 6 or 8 spindle models with production table, hand feed or Rockwell "up-front" power feed, key chuck or tapered spindle. Can be ordered as a unit or component parts can be ordered to enable you to make your own multiple spindle set-up with any number of spindles.

# THESE MODERN FEATURES PROVE THE SUPERIORITY OF THE NEW DELTA 17" VARIABLE SPEED DRILL PRESS!

- ① WIDEST TEST-PROVEN SPEED RANGE
- ② "STABILIZER-CONTROLLED" SPEED CHANGES
- ③ 25 TO 28% GREATER POWER TRANSMISSION EFFICIENCY
- ④ EXCLUSIVE NEW CONCEPT DEPTH STOP
- ⑤ UNIQUE DOUBLE SPINDLE

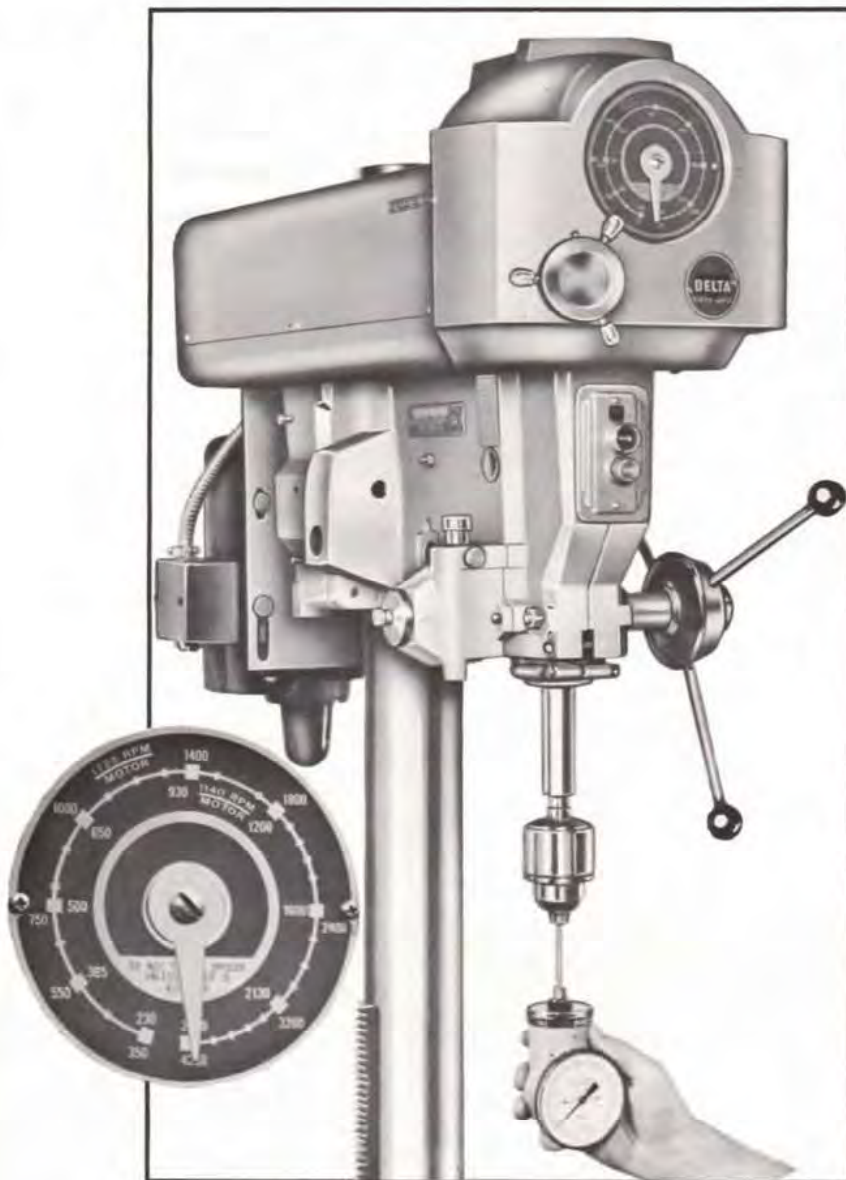

**Drill Ferrous Metals**



**Drill Non-ferrous Metals**



**Drill Building Board**



**Drill Plastic**



**Drill Wood**

① You can prove the tremendous 12 to 1 speed ratio of the New Delta 17" Variable Speed Drill Press by actual tachometer test. You get the exact speed you need for every kind of drillable material—350 to 4250 RPM with a 1725 RPM motor—230 to 2830 RPM with an 1140 RPM motor. Large, easily-read dial permits quick, easy speed selection. Only Delta gives you a bonus of extra speeds in both the high and low speed range.



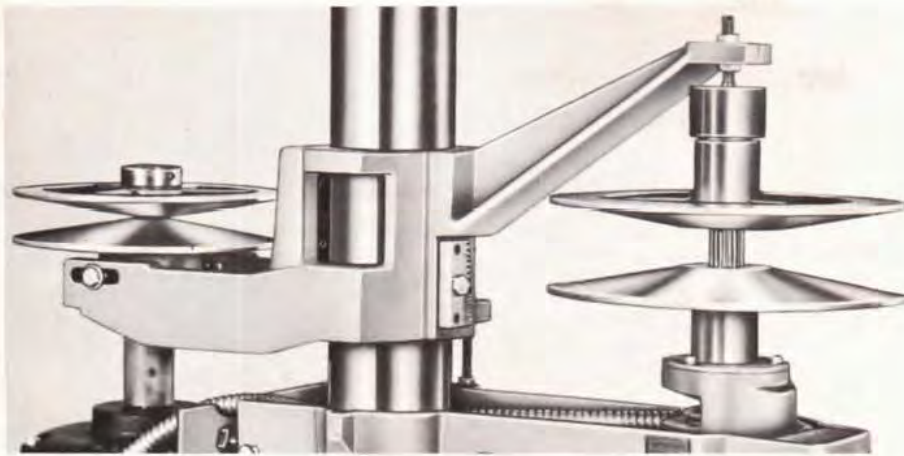

② Positive, stabilizer-speed changing control of both pulleys—without the use of springs—guarantees constant RPM's at the spindle. Pulleys can't open or close due to pulley spring pressure not matching belt pull under heavy or light work loads.

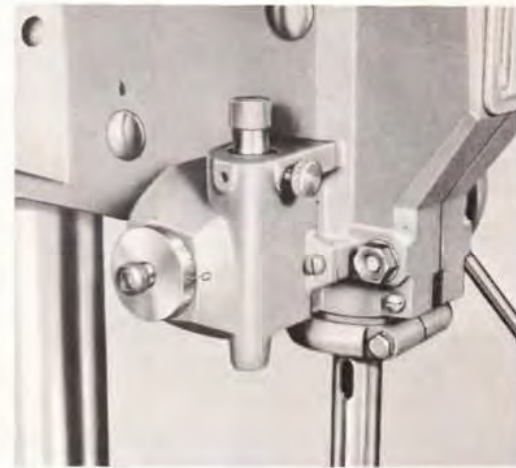

④ Eliminates quill deflection. An internal mechanism that completely eliminates the conventional, external stop rod which is clamped to the quill and which utilizes hard-to-adjust stop nuts. Delta's New Internal Depth Stop Mechanism stops the pinion shaft. It avoids all the aggravating problems, such as quill deflection at the bottom of the stroke, encountered with all old-fashioned stops.

NEW, QUICK-SET DEPTH GAGE can be set to read from zero, giving a direct reading as drill penetrates work. Scale is calibrated down to  $\frac{1}{16}$ " and magnified twice for easy reading.

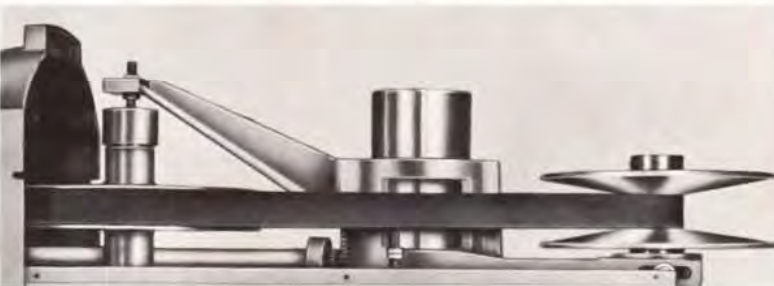

③ Delta's unique STABILIZER design assures perfect belt alignment at all speeds, not just in the mid range as with spring pulley drives. With the belt and pulleys operating in an absolutely level plane, you get 25 to 28% higher power transmission efficiency. This means more power at the drill point with lower electric power costs.

⑤ Only Delta offers a dual spindle design. Upper spindle (A) takes all belt pull and transmits torque through 16-splined free-floating drive sleeve (B) to rigid, short lower spindle (C). Five lubricated-for-life ball bearings are used—three on the upper spindle and two on the lower spindle. Short lower spindle design eliminates whipping and insures accuracy. You get chatter-free performance, even on special operations like reaming or counter-sinking.

#### ADDITIONAL DELTA QUALITY FEATURES

- Quill is rigidly supported by 3 precision-bored lands in the head, providing extra smooth travel.
- Worm screw adjustment, makes it easy to set correct tension on the spindle return spring.
- Rubber cushion ring absorbs shock between head and quill collar, or mortising chisel holder, while garter spring holds these parts on quill with light clamping pressure. This avoids quill distortion and prolongs bearing life.
- Handy, self-closing oil cup permits single point lubrication of quill surface and pinion shaft.
- All heads are machined, ready for mounting Power Feed, Foot Feed or Rack and Pinion Type Raising Mechanism.

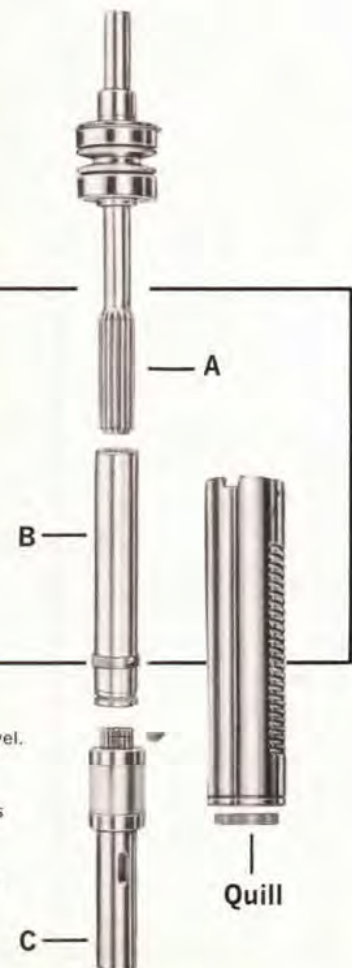

# DELTA 17" VARIABLE SPEED DRILL PRESSES

(Select Electrical Components from chart at right)

SINGLE SPINDLE MODELS	Hand Feed		Power Feed	
	No. 2 Morse Taper	1/2" Key Chuck	No. 2 Morse Taper	1/2" Key Chuck
STANDARD TABLE FLOOR MODELS	17-110 315 lbs.	17-113 315 lbs.		
*PRODUCTION TABLE FLOOR MODELS	17-116 343 lbs.	17-119 396 lbs.	17-134 383 lbs.	17-137 383 lbs.
†PRODUCTION TABLE BENCH MODELS	17-122 392 lbs.	17-125 392 lbs.	17-140 432 lbs.	17-143 432 lbs.
HEAD ONLY	17-128 155 lbs.	17-131 115 lbs.	17-146 195 lbs.	17-149 195 lbs.

\*One 3/4" pipe tap at rear

†Two 3/4" pipe taps at rear

MULTIPLE SPINDLE MODELS	Hand Feed		Power Feed	
	No. 2 Morse Taper	1/2" Key Chuck	No. 2 Morse Taper	1/2" Key Chuck
†2 Spindle One Piece Table 	17-152	17-153	17-166	17-167
	836 lbs.		926 lbs.	
*3 Spindle Sectional Table 	17-154	17-155	17-168	17-169
	1350 lbs.		1470 lbs.	
†4 Spindle One Piece Table 	17-156	17-157	17-170	17-171
	1628 lbs.		1788 lbs.	
*4 Spindle Sectional Table 	17-158	17-159	17-172	17-173
	1554 lbs.		2103 lbs.	
*5 Spindle Sectional Table 	17-160	17-161	17-174	17-175
	2140 lbs.		2360 lbs.	
*6 Spindle Sectional Table 	17-162	17-163	17-176	17-177
	2326 lbs.		2932 lbs.	
*8 Spindle Sectional Table 	17-164	17-165	17-178	17-179
	3045 lbs.		3739 lbs.	

Tables with three or more sections have three steel legs; other machines have two legs. Multiple spindle tables have 1/2" coolant trough all around. Working surface is 32" from floor. Spindle to table maximum with No. 2 M.T. or Key Chuck (jaws closed)—24 1/16".

\*3/4" Pipe Tap at each end †One 3/4" Pipe Tap at rear ‡Two 3/4" Pipe Tap at rear

## STANDARD EQUIPMENT ON ALL MODELS

Table raising mechanism on single spindle floor models  
 Head raising mechanism on multiple spindle and bench models  
 Built-in depth stop Belt Guard Depth Gage  
 All models include No. 49-159 belt and motor pulley—3/4" bore  
 Power Feed models include No. 49-126 and No. 49-117 V-belts

## MOTORS AND CONTROLS (MOUNTED)

**FACTORY RECOMMENDED ELECTRICAL COMPONENTS**—For most drill press operations it is best to order the "first choice" electrical components indicated below. Experience has shown that the "first choice" meets most situations, at the lowest price possible in line with good drilling practice.

"First Choice" for 17" Variable Speed hand feed Drill Presses

Single Phase—Order 49-440  
 Three Phase—Order 49-441

"First Choice" for 17" Variable Speed Power Feed Drill Presses

Single Phase—Order 49-444  
 Three Phase—Order 49-445

## ELECTRICAL COMPONENTS MOUNTED AND WIRED

(Motors and Push Button Switches)

HAND FEED	*Single Phase, Cap'r Start (Mounted, wired for 115V)	**Three Phase (Mounted, wired for 220V)
1725 RPM, 3/4 HP	49-440	49-441
1725 RPM, 1 HP	49-444	49-445
1725 RPM, 1 1/2 HP		49-407
1140 RPM, 3/4 HP	49-404	49-408
1140 RPM, 1 HP	49-442	49-443
1140 RPM, 1 1/2 HP		49-409

\*Includes push button switch in head and 8' cord with 3-prong grounding type plug.

\*\*Includes push button manual control switch in head.

POWER FEED	*Single Phase, Cap'r Start (Mounted, wired for 115V)	**Three Phase (Mounted, wired for 220V)
1725 RPM, 1 HP	49-444	49-445
1725 RPM, 1 1/2 HP		49-407
1140 RPM, 1 HP	49-442	49-443
1140 RPM, 1 1/2 HP		49-409

\*Includes push button switch in head and 8' cord with 3-prong grounding type plug.

\*\*Includes push button manual control switch in head.

**NOTE:** The correct electrical components should always be ordered with the 17" Variable Speed Drill Press. The belt alignment and tension as well as the adjustments for correct speed calibration are set at the factory using special gauges.

However, (for motor replacement or other reasons) motors and Push Button Switches may be ordered unmounted. For listing of motors and Push Button Switches, see below.

Manual or Magnetic starters and mounting bracket (not factory mounted) should be ordered separately and are also listed below.

## MOTORS AND CONTROLS

### FOR SINGLE PHASE OPERATION:

\*Motor, 3/4 HP, capacitor start, 115/230V, 60 cy, AC, 1725 rpm. Includes on-and-off switch, 115 V 8-foot cord and 3-prong grounding type plug. 57 lbs. No. 82-910

Motor, 3/4 HP, capacitor start, 115/230V, 60 cy, AC, 1140 rpm. Includes on-and-off switch, 115V 8-foot cord and 3-prong grounding plug. 55 lbs. No. 82-912

Motor, 1 HP, capacitor start, 115/230V, 60 cy, AC, 1725 rpm. Includes on-and-off switch, 115V 8-foot cord and 3-prong grounding type plug. 70 lbs. No. 83-510

Motor, 1 HP, capacitor start, 115/230V, 60 cy, AC, 1140 rpm. Includes on-and-off switch, 115V 8-foot cord and 3-prong plug. 70 lbs. No. 83-112

Push Button Switch. Includes 4-wire flexible conduit assembly, wiring diagram and everything needed for use with 82-910, 82-912, 83-510 or 83-112 motor. For DC use also. 3 lbs. No. 20-611

### FOR THREE PHASE OPERATION

\*Motor, 3/4 HP, 208-220/440V, 50/60 cy, AC, 1425/1725 rpm. Without switch or power cord. 43 lbs. No. 86-720

Motor, 3/4 HP, 208-220/440V, 50/60 cy, AC, 960/1140 rpm. Without switch or power cord. 47 lbs. No. 86-722

Motor, 1 HP, 208-220/440V, 50/60 cy, AC, 1425/1725 rpm. Without switch or power cord. 44 lbs. No. 86-920

Motor, 1 HP, 208-220/440V, 60 cy, AC, 1140 rpm. Without switch or power cord. 55 lbs. No. 86-922

Motor, 1 HP, 550V, 50/60 cy, AC, 1725 rpm. Without switch or power cord. 49 lbs. No. 86-930

Motor, 1 1/2 HP, 208-220/440V, 50/60 cy, AC, 960/1140 rpm. Without switch or power cord. 58 lbs. No. 87-122

Motor, 1 1/2 HP, 208-220/440V, 50/60 cy, AC, 1425/1725 rpm. Without switch or power cord. 52 lbs. No. 87-120

Switch Overload. Used with 20-613 switch. Easy to mount with 20-614 mounting bracket. Specify motor number and voltage when ordering. 3 lbs. No. 49-365

Starter, Magnetic. For 60 cy, 208-220V only. Provides low-voltage, no-voltage and overload protection. Used with 20-612 switch. Easy to mount with 20-614 mounting bracket. Specify motor number when ordering. 6 lbs. No. 49-396

Starter, Magnetic. For 60 cy, 440V only. Provides low-voltage, no-voltage and overload protection. Used with 20-612 switch. Easy to mount with 20-614 mounting bracket. Specify motor number when ordering. 6 lbs. No. 49-397

Push Button Magnetic Control Switch. Includes 3-wire flexible conduit assembly, wiring diagram and everything needed for use with motor 86-720, 86-722, 86-920, 86-922, 86-930, 87-122 or 87-120 and magnetic starters 49-396 or 49-397. 2 1/2 lbs. No. 20-612

Push Button Manual Control Switch. Includes 6-wire flexible conduit assembly, wiring diagram and everything needed for use with motor 86-720, 86-722, 86-920, 86-922, 86-930, 87-122 or 87-120 and 49-365 overload switch. 3 lbs. No. 20-613

Bracket for mounting manual or magnetic starters on 17" Single and Multiple Spindle Drill Presses, Hand and Power Feed Models. 3 lbs. **No. 20-614**

\*Not recommended for power feed models.

**WHAT CONTROLS TO ORDER**

FOR 82-910, 82-912, 83-510 or 83-112, Single Phase Motor  
A. (115 or 230V) 20-611 only.

FOR 86-720, 86-722, 86-920, 86-922, 86-930, 87-120 or 87-122  
Three Phase Motor

- A. Manual
  - 1. (208-220/440V) 49-365, 20-613, 20-614
- B. Magnetic
  - 1. (208-220V) 49-396, 20-612, 20-614
  - 2. (440V) 49-397, 20-612, 20-614

**MAKE SPECIAL-PURPOSE MACHINES WITH THESE DELTA DRILL PRESS COMPONENTS**

- Flange**, for mounting column on table, with screws (not for floor type). 10 lbs. **NO. 1366**
- Column**, 3 1/2" diameter by 45 5/8" long. **NO. 17-816**
- Column**, 3 1/2" diameter by 69 1/8" long. **NO. 17-817**
- Column**, 3 1/2" diameter by 84 1/8" long. **NO. 17-818**
- Raising Mechanism** for head or table. Includes worm shaft, compound worm gear and pinion, crank handle, rack, thrust ball bearing and column collar. 10 lbs. **NO. 17-801**
- Production table**, one piece for 2 spindle set up. Ground work surface of 23 3/8 x 36". Fits No. 50-339 legs. 366 lbs. **NO. 1513**
- Production table**. 16 x 18" ground work surface for single spindle bench model 17" drill presses. Does not fit 50-399 legs. 120 lbs. **NO. 1514**
- Production table**, one piece for 4 spindle set up. Ground work surface of 23 3/8 x 77". Fits 50-399 legs. 804 lbs. **NO. 1515**
- Production table**, center section, 23 3/8" front to rear x 30" left to right ground work surface with 1 1/2" coolant trough. 365 lbs. **NO. 1505**

**DO MANY ADDITIONAL JOBS WITH THESE DELTA ACCESSORIES**

- LAMP ATTACHMENT**  
Uses standard 15 or 25-watt bulb. Includes mounting bracket, shade, socket and 115 V 8-foot cord. 1 1/2 lbs. **NO. 882**
- PRODUCTION TABLES**  
12 1/2 x 17" with solid, ground work surface (including coolant trough, 16 x 20 1/2"). Table has 1 1/2" coolant trough with one 3/4" pipe tap drain hole at left rear corner. Tilts 17° right and left and fits standard bracket on floor type, single spindle drill presses. 57 lbs. **NO. 1372**
- 12 1/2 x 17" ground work surface (including coolant trough, 16 x 20 1/2") with two parallel T-slots for 1/2" T-bolts. Slots are on 9" centers and run from front to back. Table has 1 1/2" coolant trough with one 3/4" pipe tap drain hole at left rear corner. Tilts 17° right and left and fits standard bracket on floor type, single spindle drill presses. 65 lbs. **NO. 17-825**
- RAISING MECHANISM**  
For head or table. Includes worm shaft, compound worm gear and pinion, crank handle, rack, thrust ball bearing and column collar. 10 lbs. **NO. 17-801**
- FOOT FEED**  
For floor type single spindle model. 35 lbs. **NO. 1371**

**POWER FEED ATTACHMENT FOR CONVERTING ANY DELTA NEW STYLE 17" HAND FEED DRILL PRESS OR HEAD TO POWER FEED.** (Cannot be used with old style heads. Heads lacking front opening for push button switch are old style.) Consists of power feed mechanism, jack shaft assembly with pulleys, idler pulley assembly, stop rod assembly, pinion shaft, quill collar and guide for stop rod, 49-117 and 49-126 V-belts. Includes instructions for field mounting. 55 lbs. **NO. 17-800**

**AUTOMATION AND REMOTE CONTROL KIT FOR DELTA 17" and 20" POWER FEED DRILL PRESSES.** Includes 220 volt, 60 cycle, single phase solenoid; mounting bracket; lever arm with shaft and instructions for field mounting. (Fits only newer power feed machines having "up-front" three-spoke manual control mechanism, as illustrated.) 17 lbs. **NO. 49-436**

**AUTOMATION AND REMOTE CONTROL KIT FOR DELTA 17" and 20" POWER FEED DRILL PRESSES.** Same as 49-436, except 440 volt. 17 lbs. **NO. 49-437**



- Production table**, end section, 23 3/8" front to rear x 32 1/2" left to right ground surface with 1 1/2" coolant trough and 3/4" pipe tap at end. 352 lbs. **NO. 1507**
- Floor Rest** for multiple spindle drill press tables. Consists of 2 3/4" column, base and V-pad which adjusts from 27 1/2 to 29 1/2". Recommended to prevent table sag, especially for 4-spindle and longer machines. 20 lbs. **NO. 50-401**
- Legs**, steel, one pair, 27 1/2" high for mounting tables 1513 and 1515, also table sections 1505 and 1507 100 lbs. **NO. 50-399**
- Leg**, steel, 27 1/2" high for mounting production tables and sections. Cannot be used with 14" Super-Hi drill press tables. 50 lbs. **NO. 50-506**
- Riser Blocks**, cast iron, one pair, 2" high with studs, nuts and lock washers for mounting under legs 50-399 and 50-506. **One pair required for each single leg** to raise machine 2". Two blocks can be stacked to raise machine 4". 8 lbs. **NO. 50-400**

- SLO-SPEED ATTACHMENT**  
Provides 4.7 to 1 speed reduction for spot facing, reaming, counterboring, core drilling, etc. Fits No. 2 M.T. spindle models only. Speed range with 1725 rpm motors: 80 to 2240 rpm with slo-speed models; 150 to 4250 rpm with high-speed models. Spindle travel with this attachment is 4". 10 lbs. **NO. 17-860**
- SPINDLE**  
No. 3 M.T., with bearings. Includes instructions for installing on Delta 17" Drill Press. 3 lbs. **NO. 17-880**
- MORTISING ATTACHMENT**  
Fits key chuck models only. Consists of a heavy fence bolted to the drill press table. Two hooked rods hold work against fence and an adjustable hold-down keeps the work from being raised when the chisel is withdrawn. Capacity under hold-down—6 1/2", from ends of hooked rods to fence—2 1/2". Foot feed 1371 recommended for mortising. 19 lbs. **NO. 1381**
- Motor Pulley Assembly**, 3/4" bore. 6 lbs. **NO. 41-944**
- Motor Pulley Assembly**, 7/8" bore. 6 lbs. **NO. 41-945**
- Variable Speed Belt**, 55" O.C. 1 1/2 lbs. **NO. 49-159**

**17" VARIABLE SPEED DRILL PRESS DIMENSIONAL DATA**

17" Variable Speed Drill Press	1/2" Key Chuck and No. 2 Morse Taper Models		
	"A" Overall Height	"B" Spindle Chuck to Table (max.)	"C" Spindle Chuck to Base (max.)
Bench Type W/Production Table	52 1/16"	24 1 1/16"	—
Floor Type W/Standard Tilting Table	72 1/4"	33 3/4"	44 7/16"
Floor Type W/Production Table	72 1/4"	31 1 3/16"	44 7/16"

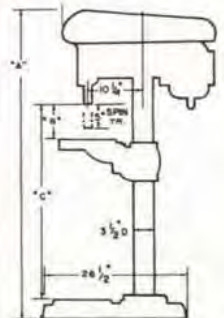



**ROCKWELL-DELTA**

**15<sup>00</sup>**

**LONG TRAVEL**

**6" STROKE**

**DRILL PRESSES**

Drill holes 35% deeper than standard 15" machines . . . offer low initial investment . . . do work of much larger drill presses while reducing cost per hole . . . increase shop production.

Here's the "all-purpose" machine for handling practically all your drill press requirements from conventional drilling to extra long, deep-hole applications.

It's ideally suited for special drilling jobs like these:

- Through holes in multiple-wall castings such as engine housings.
- I-beams and all types of extruded stock.
- Laminated sheet stock up to 6" thick.
- Structural components and parts for building construction.
- Furniture assemblies and patterns.
- Reinforcing members used in ship building and aircraft manufacture.

Typical applications like these, combined with its many superior construction features, make the New Delta 6" Stroke 15" Drill Press a favorite in industry, the building trades and in school shops everywhere.

Let us demonstrate this BIG PERFORMER for you today!

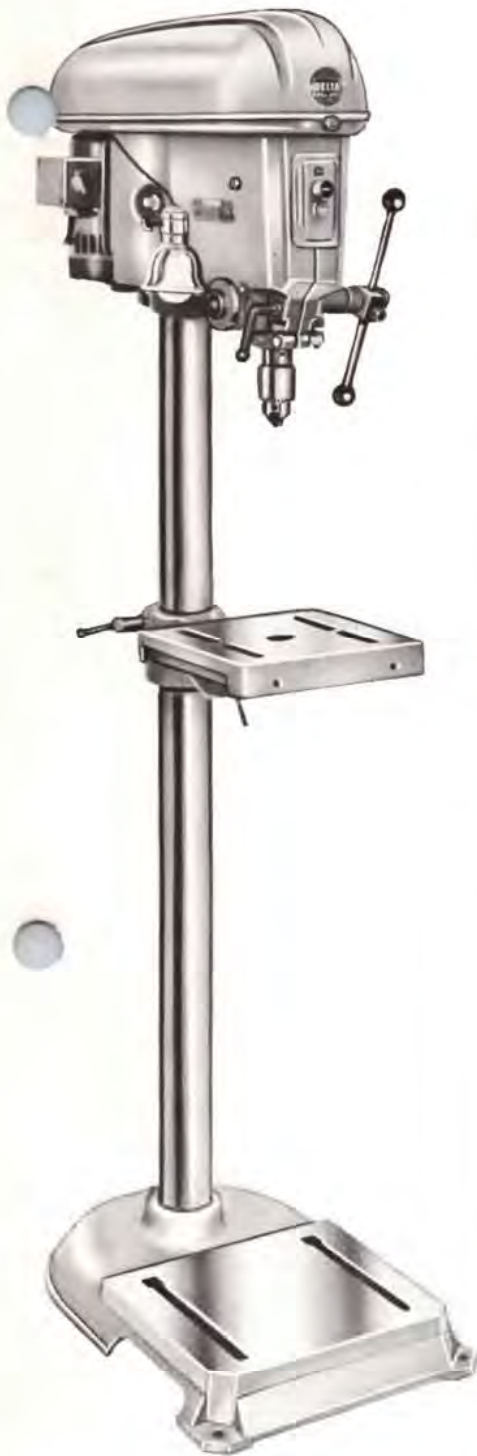

## CHOOSE FROM 40 MODELS AND GET THE MACHINE BEST SUITED FOR YOUR JOB!

**BENCH AND FLOOR MODELS . . .** with standard or production table, high or slo speed,  $\frac{1}{2}$ " key chuck or No. 2 Morse Taper spindle.

**MULTIPLE SPINDLE MODELS . . .** available in 2, 3, 4, 5, 6 or 8 spindles with production table, high or slo speed,  $\frac{1}{2}$ " key chuck or No. 2 Morse Taper spindle. Can be ordered as a unit or component parts can be ordered to enable you to make your own multiple spindle set-up with any number of spindles.

## MACHINE DATA

### Overall Dimensions:

#### Bench Type (with Standard Table):

Height..... $39\frac{1}{16}$ "  
 Width..... $13\frac{3}{8}$ "  
 Front to Rear..... $24\frac{1}{8}$ "

#### Floor Type:

Height..... $70\frac{1}{16}$ "  
 Width (Standard Table)..... $15\frac{1}{2}$ "  
 Width (Production Table)..... $21\frac{1}{2}$ "  
 Front to Rear..... $26$ "

#### Table Working Surface:

Tilting..... $10 \times 10\frac{1}{2}$ "  
 Production (Ground Surface)..... $12 \times 18$ "  
 Production (Ground Surface, Including Coolant Trough)..... $15\frac{1}{2} \times 21\frac{1}{2}$ "

#### Base Working Surface:

Bench Type..... $9 \times 10$ "  
 Floor Type..... $11 \times 13$ "

#### Quill:

Stroke..... $6$ "  
 Diameter..... $2$ "

#### Capacities:

Key Chuck..... $0$  to  $\frac{1}{2}$ "  
 Dia. Hole in Cast Iron..... $\frac{1}{2}$ "  
 Dia. Hole in Steel..... $\frac{3}{8}$ "

#### \*Spindle Nose to Table, Maximum

(Key Chuck Models):  
 Bench Type, Standard Table..... $11\frac{1}{16}$ "  
 Bench Type, Prod. Table..... $22\frac{7}{16}$ "  
 Floor Type, Standard Table..... $41\frac{3}{8}$ "  
 Floor Type, Prod. Table..... $36\frac{1}{2}$ "

#### \*Spindle Nose to Base, Maximum

(Key Chuck Models):  
 Bench Type, Standard Table..... $16\frac{9}{16}$ "  
 Floor Type..... $46\frac{1}{16}$ "

#### Spindle Speeds:

With 1725 rpm motor:  
 High Speed Model.....  
 680, 1250, 2400, 4600 rpm  
 Slow Speed Model.....  
 470, 780, 1300, 1950 rpm

#### With 1140 rpm motor:

High Speed Model.....  
 450, 825, 1585, 3040 rpm  
 Slow Speed Model.....  
 310, 515, 860, 1290 rpm

#### Column:

Wall Thickness..... $\frac{5}{32}$ "  
 Diameter..... $2\frac{3}{8}$ "

#### Motor Plate:

Accommodates NEMA Frame Motors  
 48 and 56

\*NOTE: Subtract  $\frac{1}{16}$ " for No. 2 M. T. Models.

COMPARE! YOU'LL AGREE  
 THAT YOU GET **MORE**  
 WITH THE **ALL-NEW DELTA**  
**6" STROKE 15" DRILL PRESS!**

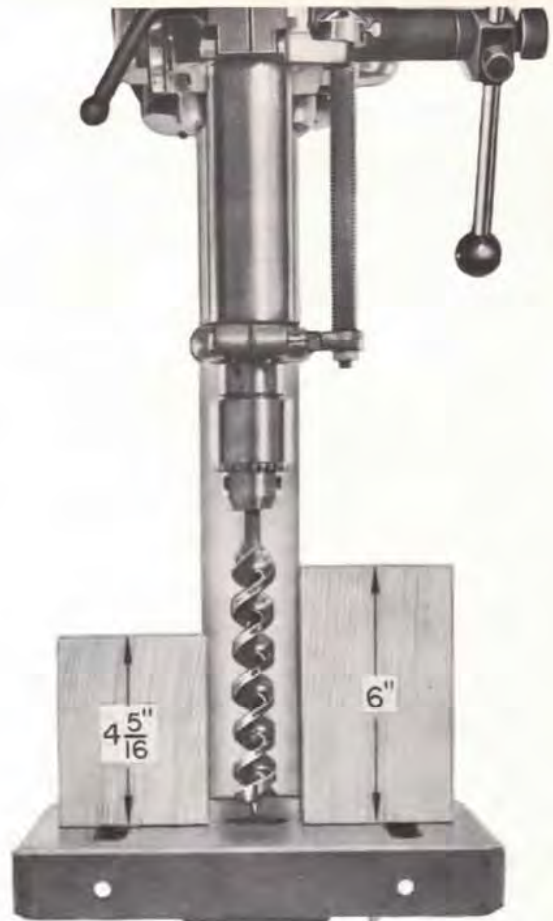

**EXCLUSIVE, "PATENTED" UNIVERSAL HAND FEED**  
 Only Delta combines the best features of the pilot wheel and single lever feeds with a unique Universal hand feed. This new feed permits positioning of the feed lever anywhere around a complete circle—less operator fatigue—freedom from striking table or fixtures—adjustable handle leverage for heavy drilling or light work—plus large handle balls for operator comfort and safety.



**EXTRA LONG QUILL TRAVEL**  
 With the Delta 6" Stroke 15" Drill Press, you get the extra depth you need for special, deep-hole drilling—a full 6" stroke. It's perfectly suited for all materials—metals, woods, composites and plastics.



**RUGGED HEAD CONSTRUCTION**  
 The head of the Delta 6" Stroke 15" Drill Press is a massive one-piece casting. This superior construction assures rigidity and stamina for production-line operations where precision accuracy and long life are required.



**MODERN BASE DESIGN**  
 Precision ground, 11 x 13" working area provides ample support and level surface for performing precision operations on extra heavy work pieces. T-slots facilitate clamping of jigs and fixtures for centering and end boring stock and for deburring tubing.

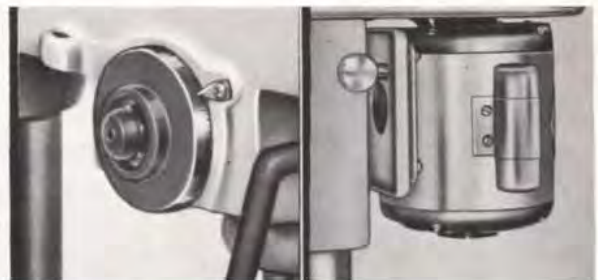

**QUICK-SET DEPTH GAGE**  
 Can be set to read from zero when drill contacts work, giving a direct reading as drill penetrates. Scale on depth gage is calibrated down to 1/32" and magnified more than two and one-half times for easy reading.

**ADJUSTABLE MOTOR MOUNTING PLATE**  
 Belt tension release is provided by the pivoting motor mounting plate which has a reverse, self-locking taper on the spring-loaded, rubber-tipped plunger that quickly restores correct belt tension.



**CONVENIENT BELT GUARD**  
 Completely encloses pulleys and belt. Guard is hinged at the rear and counterbalanced to automatically stay open, permitting easy access to belt for speed changing.

**ADVANCED TABLE DESIGN**  
 Slots and side ledges make clamping of work easy. Machined front apron has mounting holes. Tilt scale gives accurate readings to 90° right and left, and tapered, expanding bushing provides maximum gripping power for rigid positioning of table at any angle.



# ROCKWELL-DELTA 6" STROKE, 15" DRILL PRESS

## CATALOG LISTING

### SINGLE SPINDLE MODELS



Standard Tilting Table—Bench Model	Standard Tilting Table—Floor Model	Production Table—Floor Model	Production Table—Bench Model—14 x 16" Table	Head Only
<b>15-255</b> Slo-Speed 140 lbs. • #2 Morse Taper Spindle	<b>15-260</b> Slo-Speed 173 lbs. • #2 Morse Taper Spindle	<b>15-265</b> Slo-Speed 230 lbs. • #2 Morse Taper Spindle	<b>15-270</b> Slo-Speed 213 lbs. • #2 Morse Taper Spindle	<b>15-251</b> Slo-Speed 71 lbs. • #2 Morse Taper Spindle
<b>15-256</b> High Speed 140 lbs. • #2 Morse Taper Spindle	<b>15-261</b> High Speed 173 lbs. • #2 Morse Taper Spindle	<b>15-266</b> High Speed 230 lbs. • #2 Morse Taper Spindle	<b>15-271</b> High Speed 213 lbs. • #2 Morse Taper Spindle	<b>15-252</b> High Speed 71 lbs. • #2 Morse Taper Spindle
<b>15-257</b> Slo-Speed 140 lbs. • 1/2" Key Chuck Spindle	<b>15-262</b> Slo-Speed 173 lbs. • 1/2" Key Chuck Spindle	<b>15-267</b> Slo-Speed 234 lbs. • #1 1/2" Key Chuck Spindle	<b>15-272</b> Slo-Speed 213 lbs. • #1 1/2" Key Chuck Spindle	<b>15-253</b> Slo-Speed 71 lbs. • 1/2" Key Chuck Spindle
<b>15-258</b> High Speed 140 lbs. • 1/2" Key Chuck Spindle	<b>15-263</b> High Speed 173 lbs. • 1/2" Key Chuck Spindle	<b>15-268</b> High Speed 234 lbs. • #1 1/2" Key Chuck Spindle	<b>15-273</b> High Speed 213 lbs. • #1 1/2" Key Chuck Spindle	<b>15-254</b> High Speed 71 lbs. • 1/2" Key Chuck Spindle

\* Includes 1010 Safety Collar.  
† Includes No. 1008 Table Raising Mechanism.  
• 1 1/2" coolant trough with 3/4" pipe tap on each side.  
• 1 1/2" coolant trough with two 3/4" pipe taps at rear.

‡ Counter balance for raising and lowering head is included.  
High speed models include No. 49-168 V-Belt and No. 985 motor pulley—1/2" bore.  
Slo-Speed models include No. 49-167 V-Belt and No. 985 motor pulley—1/4" bore.

The 2, 3 and 4 spindle drill presses all have one piece tables. The 5, 6 and 8 spindle drill presses have sectional tables. Tables on multiple spindle units have 1 1/2" coolant trough. Working surface is 32" from the floor. Counterbalance for raising and lowering heads is included. Sectional table units with three sections have three steel legs—all other multiple spindle units have two legs.

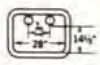
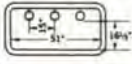
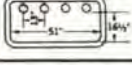
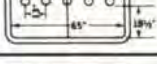
### MULTIPLE SPINDLE MODELS

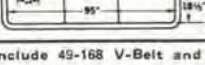
No. of Spindles		Slo-Speed #2 Morse Taper Spindle	High Speed #2 Morse Taper Spindle	Slo-Speed 1/2" Key Chuck Spindle	High Speed 1/2" Key Chuck Spindle
2 spindle— 3/4" Pipe Tap at rear		15-275 420 lbs.	15-276 420 lbs.	15-277 420 lbs.	15-278 420 lbs.
3 spindle— 3/4" Pipe Tap at rear		15-280 862 lbs.	15-281 862 lbs.	15-282 862 lbs.	15-283 862 lbs.
4 spindle— 3/4" Pipe Tap at rear		15-285 1032 lbs.	15-286 1032 lbs.	15-287 1032 lbs.	15-288 1032 lbs.
5 spindle— Two 3/4" Pipe Taps at Ends		15-290 1320 lbs.	15-291 1320 lbs.	15-292 1320 lbs.	15-293 1320 lbs.
6 spindle— Two 3/4" Pipe Taps at Ends		15-295 1770 lbs.	15-296 1770 lbs.	15-297 1770 lbs.	15-298 1770 lbs.
8 spindle— Two 3/4" Pipe Taps at Ends		15-300 1996 lbs.	15-301 1996 lbs.	15-302 1996 lbs.	15-303 1996 lbs.

High speed models include 49-168 V-Belt and 985 Motor pulley—1/2" bore  
Slo-speed models include 49-167 V-Belt and 985 Motor pulley—1/4" bore

Spindle to table maximum with No. 2 Morse Taper Spindle  
Spindle to table maximum with 1/2" Key Chuck Spindle

### MOTORS AND CONTROLS

(mounted)  
**FACTORY RECOMMENDED ELECTRICAL COMPONENTS**  
—For most drill press operations it is best to order the "first choice" electrical components indicated below. Experience has shown that the "first choice" as indicated meets most situations, at the lowest price possible in line with good drilling practice.

"First Choice" for 6" Stroke 15" Pulley—1/2" bore  
Single Phase—Order 49-438  
Three Phase—Order 49-439

### ELECTRICAL COMPONENTS MOUNTED AND WIRED

(Motors and Push Button Switches)

	*Single Phase, Cap'r Start (Mounted, wired for 115V)	**Three Phase (Mounted, wired for 220V)
	Standard Duty	Heavy Duty
1725 RPM, 1/2 HP	49-446	49-438
1725 RPM, 3/4 HP		49-447
1140 RPM, 1/2 HP	49-449	49-403

\*Includes push button switch in head and 8' cord with 3-prong ground-ing type plug. \*\*Includes push button manual control switch in head.

**NOTE:** Motors and motor controls for the Delta 6" Stroke 15" Drill Press may be ordered unmounted. For listing, see below.

### MOTORS AND MOTOR CONTROLS

#### FOR SINGLE PHASE OPERATION

**Motor, heavy duty, 1/2 HP, capacitor start, 115/230 V, 60 cy, AC, 1725 rpm.** Includes on-and-off switch, 115 V 8-foot cord and 3-prong grounding type plug. 39 lbs. **NO. 62-680**  
**Motor, heavy duty, 1/2 HP, capacitor start, 115/230V, 60 cy, AC, 1140 rpm.** Includes on-and-off switch, 115 V 8-foot cord and 3-prong grounding type plug. 40 lbs. **NO. 62-683**  
**Motor, heavy duty, 3/4 HP, capacitor start, 115/230 V, 60 cy, AC, 1725 rpm.** Includes 115 V 8-foot cord and 3-prong grounding type plug. Does not include switch. 43 lbs. **NO. 62-710**  
**Motor, standard duty, 1/2 HP, capacitor start, 115/230 V, 60 cy, AC, 1725 rpm.** Without switch, cord and plug. 20 lbs. **NO. 62-000**  
**Power Cord, 8-foot long, with 3-prong 115 V grounding type plug.** **NO. 49-357**

**Push Button Switch.** Includes 4-wire cable, wiring diagram and everything needed for use with 62-680, 62-683, 62-710 or 62-000 motor. Also may be used with DC motors. 1 1/4 lbs. **NO. 15-811**

**Switch Rod.** Includes mounting parts. Used with 62-680 or 62-683 motor (not for 62-710 or 62-000 motor) or Delta DC motors with toggle switches. Provides finger-tip control at low cost. 1 lb. **NO. 1331**

**Motor, heavy duty, 1/2 HP, 208-220/440 V, 50/60 cy, AC, 1425/1725 rpm.** Without switch or power cord. 31 lbs. **NO. 66-340**

**Motor, heavy duty, 1/2 HP, 208-220/440 V, 50/60 cy, AC, 960/1140 rpm.** Without switch or power cord. 32 lbs. **NO. 66-342**

**Motor, heavy duty, 3/4 HP, 208-220/440 V, 50/60 cy, AC, 1425/1725 rpm.** Without switch or power cord. 28 lbs. **NO. 66-710**

**Motor, standard duty, 1/2 HP, 208-220/440 V, 60 cy, AC, 1725 rpm.** Without switch or power cord. 20 lbs. **NO. 66-000**

**Switch, Overload.** Used with 15-813 switch. Easy to mount with 49-318 mounting bracket. Specify motor number and voltage when ordering. 3 lbs. **NO. 49-365**

**Starter, Magnetic.** For 60 cy, 208-220 V only. Provides low-voltage, no-voltage and overload protection. Used with 15-812 switch. Easy to mount with 49-318 mounting bracket. Specify motor number when ordering. 6 lbs. **NO. 49-396**

**Starter, Magnetic.** For 60 cy, 440 V only. Provides low-voltage, no-voltage and overload protection. Used with 15-812 switch. Easy to mount with 49-318 mounting bracket. Specify motor number when ordering. 6 lbs. **NO. 49-397**

**Push Button Magnetic Control Switch.** Includes 3-wire cable, wiring diagram and everything needed for use with motor 66-000, 66-340, 66-710 or 66-342 and magnetic starter 49-396 or 49-397. 1 lb. **NO. 15-812**

**Push Button Manual Control Switch.** Includes two 3-wire cables, wiring diagram and everything needed for use with motor 66-000, 66-340, 66-710 or 66-342 and 49-365 overload switch. 1 3/4 lbs. **NO. 15-813**

**Mounting Bracket for motor controls.** Used with 1320, 49-365, 49-393, 49-394, 49-396 and 49-397. 3 lbs. **NO. 49-318**

#### WHAT CONTROLS TO ORDER

For 62-680, 62-683 motor, single phase.  
1. (115 or 230 V) No. 15-811 only or  
2. (115 or 230 V) No. 1331 only  
For 62-710 motor, single phase  
1. (115 or 230 V) No. 15-811 only or  
2. (115 or 230 V) No. 1331 only  
49-331 (single pole type switch)  
For 62-000 motor, single phase  
1. (115 or 230 V) Nos. 15-811 and 49-357.

For 66-000, 66-340, 66-342 or 66-710 motor, three phase.  
A. Manual  
1. (208-220/440 V) Nos. 49-365, 15-813, 49-318.  
B. Magnetic  
1. (208-220 V) Nos. 49-396, 15-812, 49-318 or  
2. (440 V) Nos. 49-397, 15-812, 49-318.

## ROCKWELL-DELTA 6" STROKE, 15" DRILL PRESS

# COMPONENTS

FOR SPECIAL PURPOSE MACHINES

(See preceding pages for heads)

### COLUMNS

Column, 2 3/4" x 31", with 5/32" wall thickness. 12 lbs.	No. 14-839
Column, 2 3/4" x 33", with 5/32" wall thickness. 11 lbs.	No. 15-804
Column, 2 3/4" x 36 1/4", with 5/32" wall thickness. 13 lbs.	No. 1020
Column, 2 3/4" x 38 3/4", with 5/32" wall thickness. 15 lbs.	No. 15-805
Column, 2 3/4" x 62", with 5/32" wall thickness. 20 lbs.	No. 15-827
Column, 2 3/4" x 64", with 5/32" wall thickness. 26 lbs.	No. 15-806
Column, 2 3/4" x 78", with 5/32" wall thickness. 26 lbs.	No. 15-810
Collar, head or table support, for column. 2 lbs.	No. 1010
Flange, for mounting column on table, with screws. 10 lbs.	No. 1019
Counterbalance, complete assembly includes spring, chain, column top casting, ball bearing roller and screws. Cannot be used with columns shorter than 36 3/4". 9 lbs.	No. 1030

### TABLES

*Production Table, 14 x 16" ground work surface, for single spindle bench models. This table cannot be mounted on 50-399 Legs. 110 lbs.	No. 1516
*Production Table, 19 3/8 x 28" ground work surface, for two spindle models. For bench or floor models, fits 50-399 Legs. 274 lbs.	No. 1517
*Production Table, 21 1/4 x 51" ground work surface, for three or four spindle models. For bench or floor models, fits 50-399 Legs. 465 lbs.	No. 1519
Production Table, center section, 23 3/8" front to rear x 30" left to right ground work surface with 1 1/2" coolant trough. 365 lbs.	No. 1505
Production Table, end section, 23 3/8" front to rear x 32 1/2" left to right ground work surface with 1 1/2" coolant trough and 3/4" pipe tap at end. 352 lbs.	No. 1507
Floor Rest for Multiple Spindle Drill Press Tables. Consists of a 2 1/2" steel column, base with holes for lagging to floor, and V-pad for supporting rib of table. Screw type jack feature permits adjusting height of pad from 27 1/2 to 29 1/2 inches.	

### LEGS

Leg, Steel, 27 1/2" high for mounting production tables. 50 lbs.	No. 50-506
Legs, Steel, one pair, 27 1/2" high for mounting production tables. 100 lbs.	No. 50-399
Riser Blocks, cast iron, one pair, 2" high with studs, nuts and lock washers for mounting under legs 50-399 and 50-506. One pair required for each single leg to raise machine 2". Two blocks can be stacked to raise machine 4". 8 lbs.	No. 50-400

\*These tables can be supplied blank or drilled and tapped for mounting flange 1019.

### DIMENSIONAL DATA

15" 6" Stroke Drill Press	1/2" Key Chuck Models			No. 2 Morse Taper Models		
	"A" Overall Height	"B" Spindle To Table (max.)	"C" Spindle To Base (max.)	"A" Overall Height	"B" Spindle To Table (max.)	"C" Spindle To Base (max.)
Bench Type W/Production Table	45 13/16"	22 7/16"	—	45 13/16"	21 1/2"	—
Bench Type W/Standard Tilting Table	39 1/16"	11 1/16"	16 9/16"	38 3/4"	10 1/4"	15 3/8"
Floor Type W/Production Table	70 1/16"	36 1/2"	46 13/16"	70 1/16"	35 1/16"	45 1/8"
Floor Type W/Standard Tilting Table	70 1/16"	41 3/4"	46 13/16"	70 1/16"	40 13/16"	45 1/4"

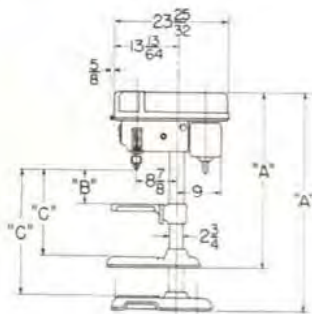

15" 6" STROKE DRILL PRESS OVERALL DIMENSIONS

## DO MANY ADDITIONAL JOBS WITH THESE DELTA QUALITY ACCESSORIES

Lamp Attachment. 1 1/2 lbs.	No. 882
Motor Pulley. Specify 1/2", 5/8" or 3/4" bore. 2 lbs.	No. 985
Head Counterbalance Attachment. 9 lbs.	No. 1030
Table, 10 x 10 1/2" ground surface, non-tilting type, with integral column bracket. Ledges at sides and slots make clamping of work easy. Holes on front apron facilitate work or fixture mounting. Fits any 15" Drill Press with 2 3/4" column. 25 lbs.	No. 15-801
Foot Feed Attachment for Floor Models only. 44 lbs.	No. 15-820
Drill Chuck with key. 1 1/2 lbs.	No. 15-830
Adapter, No. 1 M. T. 2 lbs.	No. 15-832
Adapter, No. 2 M. T. 2 lbs.	No. 15-833
Adapter, for Cup Grinding Wheels. 1 lb.	No. 15-835
Adapter, 1/2", for Shaper Cutters. 1 lb.	No. 15-836
Adapter, 1/2" Hole, for Router and Spur Bits. 1 lb.	No. 15-837
Spanner Wrench, for threaded mounting collar of Drill Chuck and Adapters. 1/4 lb.	No. 15-838
Mortising Attachment. 8 1/2 lbs.	No. 15-840
Multi-Speed Attachment, for High-Speed 15" Drill Press 5 1/2 lbs.	No. 15-848
Multi-Speed Attachment, for Slo-Speed 15" Drill Press. 5 1/2 lbs.	No. 15-849
V-Belt for Slo-Speed Models. 1/2 lb.	No. 49-167
V-Belt for High-Speed Models. 1/2 lb.	No. 49-168

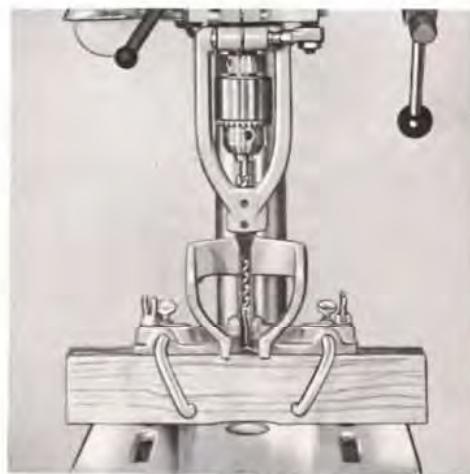
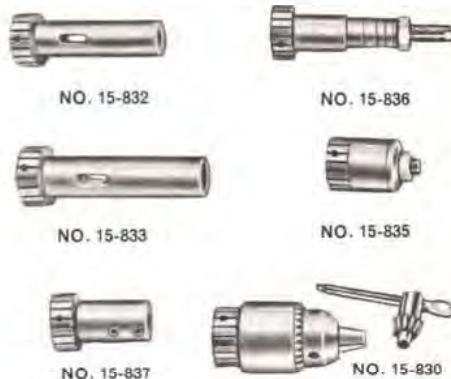

No. 15-840



# ROCKWELL-DELTA 1 HP

# 10<sup>00</sup> GRINDER

Tool rooms, experimental departments, foundries, garages and schools are just a few of the many users who appreciate the new Delta 10" Grinder. Why? Because it will capably handle all grinder operations—stock removal . . . snagging . . . sharpening of tool bits . . . shaping of special parts . . . cleaning of rust and scale . . . and dozens of additional jobs.

Here's why! This new Delta 10" Grinder incorporates all the *right* features for *quick, easy, efficient* operation, year after year.

Only Delta gives you famous Twin-Lite® Safety Shields, a modern "thin-line" motor, fully adjustable tool rests, plus heavy duty construction throughout.

Let us demonstrate this **TOP PERFORMER** for you today!



**PERFECT  
FOR INDUSTRY**



**IDEAL FOR  
SCHOOL SHOPS**

## DELTA QUALITY GRINDER EXTRAS:

Motors are dual voltage, re-connectable type. Single phase motor is preferred capacitor-start type.

New Delta 10" Grinder shown with accessory Twin-Lite® Safety Shields.

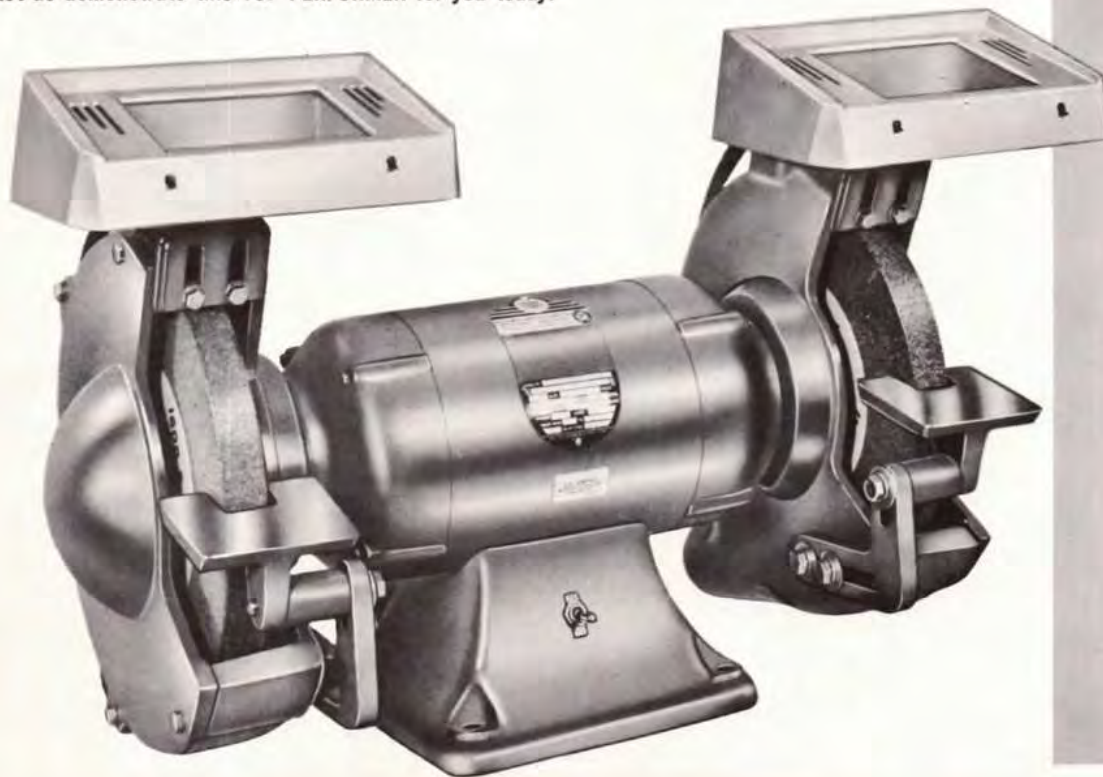

New Delta 10" Grinder shown with accessory Twin-Lite® Safety Shields and Pedestal.

## ROCKWELL-DELTA 10" GRINDER



with  
**All the  
features**



**▲ MODERN "THIN-LINE" MOTOR.** Heavy duty, dual voltage motor is slim in design, providing a full 2" space between wheels and motor, ample clearance for grinding odd-shaped items and long stock. Totally enclosed motor has double sealed ball bearings to keep out harmful abrasive dust. Twin-Lite® Safety Shields may be easily swung out of the way, yet are instantly available when required.

**FAMOUS TWIN-LITE® SAFETY SHIELDS.** Designed to operate independently of the shop lighting system, they have no equal. Double strength, shatterproof glass safeguards operator's eyes. Special spring clips prevent rattle. Bayonet type bulbs stay tight and are shielded to prevent glare. Ideally placed, they throw a full flood of light on both sides and face of wheel without casting any shadow.



**EXCELLENT SAFETY FEATURES.** This new Delta grinder, which complies with all safety codes, is unmatched for safety in design. Shatterproof glass in eyeshields, heavy cast iron guards with integral dust chutes, removable extra thick side plates and adjustable spark deflectors provide for maximum operator safety.

**MANY-PURPOSE TOOL RESTS.** Fully machined tool rests adjust both horizontally and vertically and tilt for exact grinding angle desired. They lock rigidly in place, yet may be quickly removed for accessory attachments. Note wrap-around ledges that permit grinding on sides as well as face of wheel.

### standard equipment

Grinders are furnished with two wheels, wheel guards, spark deflectors and tool rests. Single phase models are wired for 230V operation and include two-pole on-and-off toggle switch and 8-foot power cable with 230V grounding type tandem blade plug. Three phase models include 15" motor leads for power connections. **Twin-Lite® Safety Shields and bulbs must be ordered separately.**

### machine data

**MOTOR**  
Horsepower ..... 1  
RPM ..... 1725  
Shaft: Diameter ..... 3/4"  
Extends beyond Wheel Flange ..... 2 1/2"

All Motors are Dual Voltage, Re-connectable Type.

**WHEELS**  
Size ..... 10" Diameter, 1" Face, 3/4" Hole  
Balance ..... 1/8-inch ounce  
Distance Between Centers ..... 18"

**WHEEL FLANGES, DIAMETER**  
Inner ..... 3-9/16"  
Outer ..... 3 1/2"

**DIMENSIONS, OVERALL, BENCH TYPE**  
Height (Without Twin-Lites) ..... 12 1/4"  
Width ..... 24"  
Front to Back ..... 13"  
Base:

Overall Space on Bench ..... 8 1/2 x 8 1/2"  
Centers of Mounting Holes ..... 6 3/4 x 6 3/4"

**DIMENSIONS, OVERALL, PEDESTAL TYPE**  
Height (Without Twin-Lites) ..... 46"  
Width ..... 24"  
Front to Back ..... 13"  
Base:

Overall Space on Floor: Width ..... 16"  
Front to Back ..... 14"  
Centers of Floor Mounting Holes:  
Left to Right ..... 12"  
Front to Back ..... 10"

### catalog listing

No.	Type	Motor — 1 HP	Speed RPM	Motor Switch	Shipping Weight
23-100	Bench	115/230V, 60 cy. Sgl. Ph.	1725	Toggle	130
*23-101	Bench	208-220/440V, 50/60 cy, 3 Ph.	1425/1725	None	129
23-127	Pedestal	115/230V, 60 cy. Sgl. Ph.	1725	Toggle	197
§23-128	Pedestal	208-220/440V, 50/60 cy, 3 Ph.	1425/1725	Starter	201
§23-129	Pedestal	208-220/440V, 50/60 cy, 3 Ph.	1425/1725	Starter	201

\*When manual starter with overload protection is desired, use No. 1320 Manual Starter. Specify grinder catalog number and voltage when ordering starter.

§Manual Push Button Starter is shipped mounted in pedestal, with proper thermal elements for motor overload protection.

†With thermal elements for 220V operation.

‡With thermal elements for 440V operation.

### MAKE YOUR DELTA GRINDER MORE VERSATILE WITH THESE ACCESSORIES...

Aluminum Oxide Wheel, 1"x10", 36 G, grade O, 3/4" hole, balanced to 1/8-inch ounce. 10 lbs. **NO. 23-817**  
Aluminum Oxide Wheel, 1"x10", 60 G, grade O, 3/4" hole, balanced to 1/8-inch ounce. 10 lbs. **NO. 23-818**

Twin-Lite® Safety Shield (two required), with mounting block and 1/2" box connector. Without bulbs. (Order one No. 49-330 Switch when Twin-Lites® are to be used on a three phase grinder.) 6 lbs. **NO. 23-801**

Bayonet Type Lamp Bulb, 115V. Two required for each Twin-Lite® Safety Shield. 1/4 lb. **NO. 1280**  
Pedestal. Use to convert 10" Bench Grinder to pedestal type. 67 lbs. **NO. 23-805**

Plane Blade Grinding Attachment. For sharpening plane irons, wood chisels, etc. 6 lbs. **NO. 1294**  
Wheel Dresser Holder. Used with No. 3121 Wheel Dresser. 1 lb. **NO. 1664**

Diamond Pointed Wheel Dresser. Should be used with No. 1664 Holder. 1 lb. **NO. 3121**

Dust Collector for single phase operation, 1/2 HP, 115/230V, 60 cy, 3450 rpm. Includes on-and-off switch, switch rod, 115V 8-foot cord and 3-prong grounding type plug, mounted and wired. 120 lbs. **NO. 49-520**

Dust Collector for three phase operation, 1/2 HP, 208-220/440V, 50/60 cy, 2850/3450 rpm. Includes 3-pole on-and-off switch, switch rod, 8-foot cord and 220V 3-prong "crowfoot" type plug, mounted and wired. 120 lbs. **NO. 49-521**

Extra Standard Filter for dust collector. 8 lbs. **NO. 49-529**  
Holder with two expanded fiber filter pads for dust collector. Recommended for fine dust. 7 lbs. **NO. 49-531**

Twenty-four Expanded Fiber Filter Pads in carton. For fine dust. 15 lbs. **NO. 49-532**  
Attachment Package for dust collectors. 8 lbs. **NO. 23-802**

Flexible Rubber Hose for dust collector. 2-5/16" I.D. x 20" long. 2 lbs. **NO. 49-533**  
Flange for 2-5/16" hose. 2 1/2 lbs. **NO. 49-538**

Hose Clamp, adjustable. 1/2 lb. **NO. 49-541**  
Manual Starter, 3 phase, size O, NEMA type 1 enclosure, rated 2 HP, 208 to 550V, AC. 6 lbs. **NO. 1320**

Two-Pole Toggle Switch, one hole mounting, bat type lever. Required for separate on-and-off control of No. 23-801 Twin-Lites® when used on three phase grinders. 1/4 lb. **NO. 49-330**



NO. 23-818



NO. 1664 and NO. 3121



NO. 1294

# ROCKWELL-DELTA

## 6<sup>00</sup> TOOL GRINDER

AS A SMALL SHOP OWNER YOU CAN DO YOUR OWN GRINDING ECONOMICALLY AND QUICKLY, RIGHT IN YOUR OWN SHOP, THE WAY YOU PREFER. It *reduces operating costs* because it makes possible internal grinding, therefore, a smaller investment in tools is required. It *increases production*. There's no loss of production time because tools are ground right in the plant. It *increases efficiency*. Tools can be sharpened to exact specifications without delay.

AS A LARGE SHOP OWNER YOU CAN USE THE DELTA 6" TOOL GRINDER TO RELIEVE THE BOTTLENECK ON YOUR LARGER GRINDERS. When the tool room has your large grinders tied up, you can use the Delta Grinder to handle the smaller jobs. The use of smaller grinding wheels will save dollars in wheel costs, particularly when diamond wheels are used.

AS A SCHOOL SHOP INSTRUCTOR YOU CAN TEACH ACCURATE GRINDING ON THE DELTA 6" TOOL GRINDER. When you ask your students to grind a specific rake, clearance, or point angle, there will be no guesswork on their part. They can get it by setting the table and the sliding angle jig. Their work will have a single face, not many faces. Your students' work will meet the high standards you demand.

WITH A DELTA 6" TOOL GRINDER YOU CAN SHARPEN TOOLS TO YOUR OWN SPECIFICATIONS. As a tool-maker, model maker, lathe operator or maintenance man, you can do precision grinding or diamond finishing of carbide-tipped tool bits, high-speed, alloy steel or carbon steel single-point cutting tools right in your plant to keep work moving through your shop. This inexpensive grinder also is ideal for sharpening boring bars, star drills, blades, and for roughing multiple point tools.

### DELTA QUALITY GRINDER EXTRAS . . .

- To assure smooth, vibration-free operation, aluminum wheel flanges are dynamically balanced, then faced off after assembly. Light in weight, they permit quicker starting and stopping. A ring is provided to automatically center wheels when mounted. Flanges have two sets of mounting holes, one for silicon-carbide or aluminum-oxide wheels and one for diamond wheels.
- Lamp Attachment has a flexible gooseneck for providing a full flood of light at the four grinding points. Nylon cool-shield on lamp prevents burned fingers.



Wheel Centering Ring Shown in Place.

Wheels Not Furnished With Grinder (Order Separately).

- Handy Water Pot With Faucet conveniently mounts on either side. A tapered brass mounting post securely holds it in place.
- Balanced motor, and wheels which are balanced to within  $\frac{1}{8}$  inch ounce, assure extra smooth operation.

FOR DELTA QUALITY FEATURES, SEE NEXT PAGE . . .

19



## 1 SPECIALLY-DESIGNED MOTOR

Totally enclosed motor has heavy, integrally cast end bells which double as husky, safe wheel guards. All motors are dual voltage, re-connectable type. Single phase motors are powerful capacitor-start type that won't dim lights and that reach full grinding speed quickly.

## 3

### HUSKY, EXTRA LARGE TABLES

Made of cast iron, they ride on widely spaced trunnions for maximum rigidity in operation. Easy-to-read scales at both ends facilitate tilting to 30° in and 45° out for grinding cutter bit angles easily, accurately and safely. A 1/2" x 3/16" groove accommodates jigs and fixtures. Wheel changing is easy because tables lift off machine without need for using wrenches.



### ACCESSORIES

**WHEEL**, 1 x 6", 60 grit, silicon-carbide, grade H 12, 1" face, 1/4" hole. 10 lbs. **NO. 1661**

**WHEEL**, 1 x 6", 120 grit, silicon-carbide, grade H 12, 1" face, 1/4" hole. 10 lbs. **NO. 1662**

**WHEEL**, 1 x 6", 46 grit, aluminum-oxide (for roughing), grade G, 1" face, 1/4" hole, 10 lbs. **NO. 23-841**

**WHEEL**, 1 x 6", 80 grit, aluminum-oxide (for finishing), grade J, 1" face, 1/4" hole, 10 lbs. **NO. 23-842**

**Pedestal**, for Grinder. 69 lbs. **NO. 23-805**

**Wheel Dressing Tool**, diamond pointed. 1 lb. **NO. 3121**

**Holder**, for Diamond Wheel Dresser. 1 lb. **NO. 1664**

**Lamp Attachment**, complete. Same as furnished with machine. With 15" flexible gooseneck and nylon cool-shield. 2 lbs. **NO. 25-857**

**Water Pot**, with faucet. Same as furnished with machine. 5 lbs. **NO. 1663**

**Sliding Angle Jig**. Same as furnished with machine. 4 lbs. **NO. 31-804**

## 4

### MOTOR BEARINGS PROTECTED 5 WAYS

It is impossible for water or abrasive grit to reach the motor bearings. Here's why: (1) Neoprene slinger washer throws water off by centrifugal force. (2) Positive contact of washer against seal closes opening to labyrinth. (3) Labyrinth type, centrifugally designed bearing seal interlocks with wheel flange. (4) Space between labyrinth seal and motor bearing is packed with grease. (5) Actual motor bearing is sealed as final protective measure.

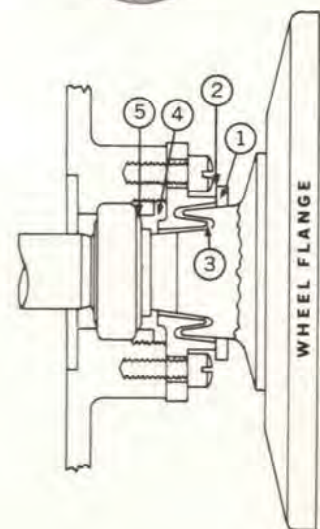

## 2

### HANDY BRAKE; CONVENIENT REVERSING SWITCH

Positive brake quickly stops wheels to save valuable production time. Switch instantly reverses wheel rotation so wheel is turning downward at both front and rear grinding points. Therefore, operator's hands are always safely placed outside and away from upward traveling face of wheel.





## 5

### QUICK-RELEASE COOLANT PANS

Designed to catch all water and sludge. Spring-clip mounting permits their instantaneous removal for washing away from grinder. This saves operator's time, also keeps machine and working area clean and dry for added safety.



## 6

### SPECIALLY DESIGNED SLIDING ANGLE JIG (Standard Equipment)

Tilt angle scale, with adjustable pointer, facilitates accurate grinding of compound angles up to 45°, right or left. Movable face plate can be adjusted to bring support of cutting tool as close to wheel as desired. This feature assures better grinding with greater safety for the operator.



## 7

### DIAMOND POINTED WHEEL DRESSER

This accessory dresses aluminum oxide and silicon carbide wheels. With the aid of the Wheel Dressing Tool Holder, it quickly sharpens the face of the wheel and trues it exactly parallel to table groove. Thus, tool bits can be sharpened to exact specifications.

## MACHINE DATA

### MOTOR

Horsepower..... $\frac{1}{2}$   
 Totally Enclosed (TENV)  
 All Motors are Dual Voltage with Reconnectable Feature. Single Phase Motors are Capacitor Start type.

### WHEELS RECOMMENDED

Size: 6" Diameter, 1" Thick, 1" Face, with  $\frac{1}{4}$ " Hole  
 Type: Plate Mounted (D6A2C Diamond Wheels)  
 Bolt Circle..... $\frac{3}{4}$ "  
 Holes in Plate (4)  
 For Diamond Wheels  $\frac{3}{8}$ ", Countersunk  
 For Sil. Carb. and Alum. Ox. Wheels..... $\frac{1}{2}$ ", Straight

### WHEEL FLANGES

6" Diameter, Tapped for Mounting Wheels  
 Aluminum, Dynamically Balanced

### TABLES

Tilt.....45° Out and 30° In  
 Size..... $7\frac{1}{4}$  x  $12\frac{3}{4}$ "  
 Groove for Sliding Angle Jig..... $\frac{3}{8}$  x  $\frac{1}{2}$ "

### DIMENSIONS, OVERALL, BENCH TYPE

Height (Without Lamp)..... $14\frac{1}{4}$ "  
 Width..... $24\frac{3}{4}$ "  
 Front to Back.....15"  
 Base  
 Overall Space on Bench..... $8\frac{1}{2}$  x  $8\frac{1}{2}$ "  
 Centers of Mounting Holes..... $6\frac{3}{4}$  x  $6\frac{3}{4}$ "

### DIMENSIONS, OVERALL, PEDESTAL TYPE

Height (Without Lamp)..... $47\frac{1}{4}$ "  
 Width..... $24\frac{3}{4}$ "  
 Front to Back.....15"  
 Base  
 Overall Space on Floor  
 Width.....16"  
 Front to Back.....14"  
 Centers of Floor Mounting Holes  
 Left to Right..... $11\frac{1}{8}$ "  
 Front to Back.....10"

## CATALOG LISTING

No.	Type	Motor— $\frac{1}{2}$ HP	Speed RPM	Ship. Wt. Lbs.
23-501	Bench	115/230 V, 60 Cy, Sgl. Ph.	3450	90
23-503	Bench	208-220/440 V, 50/60 Cy, 3 Ph.	2850/3450	90
23-521	Pedestal	115/230 V, 60 Cy, Sgl. Ph.	3450	157
23-523	Pedestal	208-220/440 V, 50/60 Cy, 3 Ph.	2850/3450	157

## STANDARD EQUIPMENT

All models have one each lamp attachment, water pot, sliding angle jig and on-and-off reversing switch. Single phase models are wired for 115 V operation and include 115 V 8-foot grounding cord and 3-prong plug. **NOTE:** When overload protection is desired, use No. 49-365 Overload Switch. Specify grinder catalog number and voltage when ordering switch.

# ROCKWELL-DELTA

## 1/2 HP long-shaft Buffer

with ALL the right features  
to let you do MORE!

A precision-built machine, this new buffer will perform efficiently year after year, even under the most demanding shop conditions. Check its Delta quality Features:

- Unique oval end bell hubs and the extra long shafts which extend  $3\frac{15}{64}$ " from bearing seal to wheel flange provide more room for handling large or oddly shaped work pieces.
- Slim designed, "Thin-Line" motor and extended shafts assure ample clearance for buffing long stock. Totally enclosed motor incorporates double sealed ball bearings, plus an extra seal to keep out harmful dust.
- Capacitor start, 115/230V, single phase motor requires low starting current. It won't dim lights like split-phase motors.

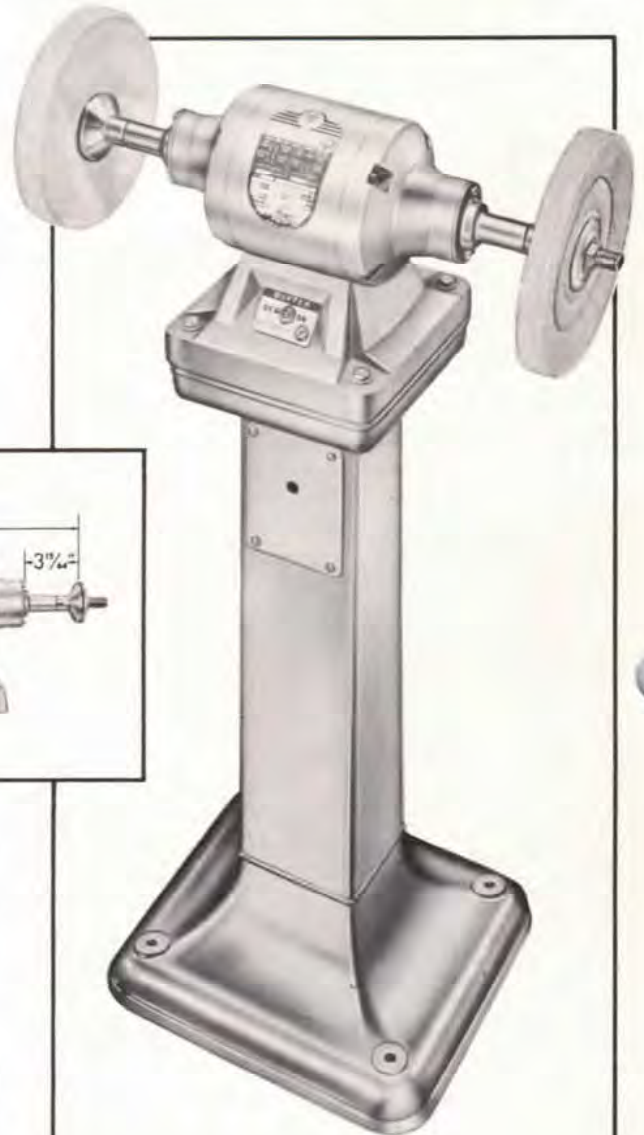
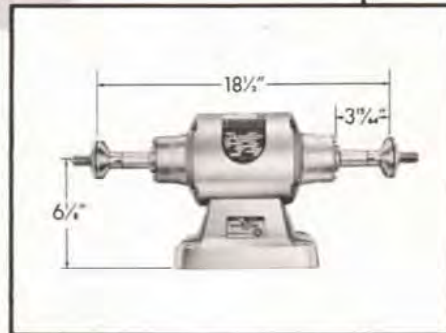

Long Shaft Buffer  
Shown on No. 23-805  
Pedestal (Accessory).

### CATALOG LISTING

No.	Type	Motor	Speed RPM	Motor Switch	Ship. Wt.
*23-233	Bench	115/230V, 60 Cy, Sgl. Ph.	3450	Toggle	48
*23-234	Bench	115/230V, 60 Cy, Sgl. Ph.	1725	Toggle	48
‡23-235	Bench	208-220/440V, 50/60 Cy, 3 Ph.	3450	None	48
‡23-236	Bench	208-220/440V, 50/60 Cy, 3 Ph.	1725	None	48

\*Single phase models are wired for 115V operation and include on-and-off switch with 115V 8-foot grounding cord and 3-prong plug.  
‡When manual starter with overload protection is desired, use No. 1320 Manual Starter. Specify buffer catalog number and voltage when ordering starter.

### MACHINE DATA

Horsepower ..... 1/2  
 Shaft:  
 Diameter ..... 3/8" Extends beyond flange ..... 2 1/2"  
 Frame Diameter ..... 5 3/2"  
 Distance between faces of wheel flanges ..... 18 1/2"  
 Distance from bearing seal to wheel flange face ... 3 15/64"

Centerline of spindle to bottom of base ..... 6 1/8"  
 Diameter of wheel flange ..... 2 1/2"  
 Overall Dimensions:  
 Base ..... 8 1/2 x 8 1/2" Depth ..... 11"  
 Width ..... 23 1/2" Height ..... 13 3/4"

The  
**PERFECT**  
 Answer  
 for  
**ALL**  
 Your  
**Buffing**  
**NEEDS!**



**IN INDUSTRY**—Oval end bell hubs and extra long shafts facilitate the removal of rust and burrs from odd-shaped castings and parts.



**IN COMMERCIAL SHOPS**—Plastic manufacturers find the New Delta Long-Shaft Buffer an excellent unit for turning down, polishing and coloring plastic pieces and components.



**IN REPAIR SHOPS**—Appliance shops appreciate the extra amount of clearance between the motor and the buffing wheel when cleaning and polishing bulky items such as sweeper housings.



**IN SPECIALTY AND "PRO" SHOPS**—The new Delta Buffer is ideal for removing rust and tarnish from golf clubs, guns, etc., to provide a factory-new surface in just minutes.

Your Buffer does many jobs  
 with these **DELTA ACCESSORIES**

**Pedestal**, cast iron, 26" high. Base is 14" front to back and 16" left to right. 67 lbs. **NO. 23-805**

**A** 8" **Buffing Wheel** for 5/8" arbor, 3/4" face, 48 ply, fine muslin, cushion type with three circles of lock-stitched sewing. Includes one pair of toothed flanges for 5/8" arbor and instructions for use. A professional quality, general purpose buff recommended for light cutting down and for finish coloring. 1 lb. **NO. 23-825**

**B** **Wire Brush**, 6" diameter, fine, 5/8" hole. 1 lb. **NO. 1236**

**C** **Wire Brush**, 6" diameter, medium, 5/8" hole. 1 lb. **NO. 1237**

**D** **Wire Brush**, 6" diameter, coarse, 5/8" hole. 1 lb. **NO. 1238**

**Red Rouge Buffing Compound**, one pound bar, with instructions. Recommended for coloring gold, silver and other precious metals. 19 oz. **NO. 4007**

**White Rouge Buffing Compound**, one pound bar, with instructions. Recommended for cutting down and coloring stainless steel,

steel, chromium, nickel plate, brass, aluminum and plastics. 19 oz. **NO. 4008**

**Emery (black) Buffing Compound**, one pound bar, with instructions. Recommended for coarse polishing to remove rust, scale, scratches and burrs from iron, steel and other hard metals. 19 oz. **NO. 4009**

**Tripoli (brown) Buffing Compound**, one pound bar, with instructions. Recommended for cutting down and coloring of aluminum, brass, copper, pewter, plastics, hard rubber, animal horn and wood. 19 oz. **NO. 4010**

**E** **Buffing Compound Kit**, four 1/4 pound bars, with instructions. Includes one each of Red Rouge, White Rouge, Emery and Tripoli bars. 19 oz. **NO. 4004**



# NEW ROCKWELL-DELTA SANDER/GRINDER

**PERFORMS UNLIMITED OPERATIONS**—Perfectly suited for all users, it can be used on wood, metal, plastics, leather, rubber, ceramics, and compositions to do dozens of jobs like these: Sanding or grinding to a line . . . deburring parts and pieces . . . contouring to a desired shape . . . finishing for painting or plating . . . polishing the finished product . . . sharpening cutting edges . . . cleaning intricate or inside edges.

**DOES WORK OF MANY MACHINES**—This one low-cost machine will do the work of the band saw, jig saw, coping saw or hand file, only better. It sands at amazing speed while giving perfect results. It's more flexible than the grinder, too, because it can be used to sand or grind internal or external surfaces with or without the platen.

**COMPLETE PORTABILITY**—can easily be moved from one location to another—no lost production time!

**BELTS ARE BETTER THAN ANY OTHER METHOD—BECAUSE:**

- they cut faster—result in sharper, faster cutting action than conventional grinding wheels.
- they operate cooler—you get increased production with longer belt life.
- they give better quality—sharper grain structure, cooler operation, custom-selected belt all result in better quality finish.
- wide variety of belts available—you can select a specific belt for material being worked and finish desired.

**YOU GET MORE OF THE QUALITY YOU WANT WITH A ROCKWELL-DELTA SANDER/GRINDER . . . AND THE COST IS LOW!**

The wide versatility, together with the excellent features built into the Rockwell-Delta Sander/Grinder, makes it an ideal machine for *every* shop—toolroom . . . pattern shop . . . foundry . . . school shop . . . even the home workshop. Although Rockwell-Delta quality constructed throughout, you'll be amazed at its *exceptionally low price!* Investigate this **BIG VALUE** today!



Portable Model Shown With Motor, Mounted on Metal Base Plate.



Basic Sander/Grinder Unit



Floor Model Shown With Motor and Switch, Mounted on Steel Stand, with Casters.

## MACHINE DATA

### Overall Dimensions

Bench Type (without 31-360 Plate)  
Height—18½"; Width—8½";  
Front to Rear—12"

Floor Type (on 50-106 Stand)  
Height—50"; Width—14";  
Front to Rear—19"

Table  
Size—7" deep x 8" wide; with  
1½ x ¾" slot  
Tilts . . . . . 10° in; 90° out  
Height from Bench—8¾"; (with 31-360  
plate) . . . . . 9½"  
Height from Floor (on 50-106 Stand) . . . . . 40¼"

### Capacities

Belt to Column . . . . . 7½"  
Table to Upper Idler (inside grinding,  
with 44" belt) . . . . . 3"

### Abrasive Belt

Length  
Min.—40"; Std.—42"; Max.—44"  
Width  
Min.—½"; Max.—1"  
Speed (with contact wheel)—4600 sfpm;  
Std.—4000 sfpm.

Diameter of Drive Shaft (both ends) .627"  
Motor Recommended . . . 3450 rpm; ½ HP



**TALK ABOUT VERSATILITY! Sanding • Sharpening • Contouring • Deburring • Grinding • Finishing • Polishing DOES ALL THESE JOBS EASIER . . . FASTER . . . BETTER.**



**Toolroom . . .** grinds cutting tools to exact specifications.



**Plating Department . . .** polishes die cast aluminum housing prior to plating.



**Foundry . . .** using contact wheel, aggressively removes flash and excess stock.



**Pattern Shop . . .** narrow band gets into small openings . . . finishes patterns rapidly to close tolerances.



**School Shop . . .** enables students to contour plastic parts perfectly.



**Home Workshop . . .** sharpens kitchen knives and other household items in only minutes.



**Electronics Laboratory . . .** perfectly touches up parts for precision assembly.



**Assembly Department . . .** quickly removes sharp edges on metal stampings, even in small openings.



**Sign Shop . . .** after quickly threading belt, internal sanding becomes an easy operation.



**Scissors Manufacturer . . .** using narrow belt, and without platen, internal grinds rounded edges with ease.



**Golf Pro Shop . . .** quickly removes rust to make golf irons look like new.



**Industrial Plant . . .** rapidly deburrs sharp edge following stock cut-off with abrasive wheel.

**CATALOG LISTING**

Basic Sander/Grinder with table, one flat platen for 1" belts, 2" arbor V-pulley and one 1 x 42", 80 grit, aluminum oxide belt. 26 lbs. **No. 31-350**

Single Phase Sander/Grinder Portable Unit Complete. Consists of 31-350 Basic Machine, 49-105 V-belt, 5250 Motor Pulley, 31-360 Base and 60-050 Motor. Completely assembled and ready to plug in on 115 V, 60 cycle, single phase. 56 lbs. **No. 31-355**

Three Phase Sander/Grinder Portable Unit Complete. Consists of 31-350 Basic Machine, 49-105 V-belt, 5250 Motor Pulley, 31-360 Base and 66-060 Motor. Completely assembled. 54 lbs. **No. 31-356**

**MOTORS AND CONTROLS**

**For Single Phase Operation**

Motor, 1/2 HP, 115 V, 60 cycle, AC, 3450 rpm, 1/2" single shaft, sleeve bearing, 6" frame, guarded drip proof enclosure, 50°C temperature rise, with manual re-set type integral overload protection. Includes on-and-off toggle switch and 115 V 8-foot cord with 3-prong grounding type plug. 25 lbs. **No. 60-050**

Switch Box and 2-wire Cable. For use with 60-050 Motor. Provides up-front remote control utilizing the Toggle Switch and 8-foot cord furnished with the motor. 1 lb. **No. 49-385**

Switch Rod for use with 60-050 Motor on steel stand. 1 lb. **No. 1330**

**For Three Phase Operation**

Motor, 1/2 HP, 208-220/440 V, 60 cycle, AC, 3450 rpm, 1/2" single shaft, sleeve bearing, 6" frame, guarded drip proof enclosure, 50°C temperature rise. Without switch or power cord. 23 lbs. **No. 66-060**

Starter, Manual. Provides overload protection. Specify motor number and voltage when ordering. 6 lbs. **No. 1320**

Starter, Magnetic. For 60 cy, 208-220 V, AC only. Provides low-voltage, no-voltage and overload protection. Specify motor number when ordering. 6 lb. **No. 49-393**

Starter, Magnetic. For 60 cy, 440 V, AC only. Provides low-voltage, no-voltage and overload protection. Specify motor number when ordering. 6 lbs. **No. 49-394**

Mounting Bracket for mounting manual or magnetic starters on 50-106 Steel Stand. 3 lbs. **No. 49-318**

Cable Kit, three-wire type, 3-foot long, with clamp fittings. Used for wiring man-

ual or magnetic starters to 66-060 Motor. 1 lb. **No. 49-315**

**ACCESSORIES**

V-belt, 30 1/8" O.C. Used with 31-360 Base or for rear motor position on customer's bench. 1/2 lb. **No. 49-105**

V-belt, 47 3/8" O.C. Used with 50-106 Steel Stand. 3/4 lb. **No. 453**

Motor Pulley, 2 1/2" diameter (specify 1/2", 3/8" or 3/4" bore). 1/2 lb. **No. 5250**

Metal Base Plate, 8-1/2 x 17". Drilled for mounting Sander/Grinder and motor, and for mounting Base Plate to work bench. 11 lbs. **No. 31-360**

Open Steel Stand, with shelf for motor, for Sander/Grinder. 34 lbs. **No. 50-106**

Guard for Arbor Pulley. Can be used for rear or underneath motor position. Includes mounting screws and washers. 4 lbs. **No. 31-361**

Rubber Contact Wheel, 4" diameter, 1" face, special bore size, with set screw, 60 durometer, with 45° standard serrations. A general purpose wheel recommended for both stock removal and rough finishing. Can be used for flash grinding on soft metals. 1 lb. **No. 31-362**

Flat Platen for 1" belts. 1/4 lb. **No. 31-363**

Flat Platen for 1/2" or narrower belts. 1/4 lb. **No. 31-364**

Convex Platen, 1/2" radius, for 1" belts. 1/4 lb. **No. 31-365**

Abrasive Belt, aluminum oxide, package of 5, 1 x 42", 40 grit (coarse), cloth backing, closed coat. 1/2 lb. **No. 31-370**

Abrasive Belt, aluminum oxide, package of 5, 1 x 42", 50 grit (coarse), cloth backing, closed coat. 1/2 lb. **No. 31-371**

Abrasive Belt, aluminum oxide, package of 5, 1 x 42", 80 grit (medium), cloth backing, closed coat. 1/2 lb. **No. 31-372**

Abrasive Belt, aluminum oxide, package of 5, 1 x 42", 120 grit (medium), cloth backing, closed coat. 1/2 lb. **No. 31-373**

Abrasive Belt, aluminum oxide, package of 5, 1 x 42", 150 grit (fine), cloth backing, closed coat. 1/2 lb. **No. 31-374**

Abrasive Belt, aluminum oxide, package of 5, 1 x 42", 220 grit (fine), cloth backing, closed coat. 1/2 lb. **No. 31-375**

Abrasive Belt, aluminum oxide, package of 5, 1 x 42", 320 grit (extra fine), cloth backing, closed coat. 1/2 lb. **No. 31-376**

Retractable Caster Set for 50-106 Steel Stand. 11 lbs. **No. 49-363**

**LOOK AT THESE IMPORTANT FEATURES:**



**Specially Designed Plastic Wheels**—The balanced, true running wheels are made of heat resistant CYCOLAC®, precision molded onto sealed, lubricated-for-life ball bearings. Wheel rims are crowned for easy belt tracking and made of wear resistant TEXIN® which is permanently bonded to the wheel body.



**Precision Ground Table**—Sturdy 7 x 8" table has a single mounting bolt for quick positioning or removal. Table tilts 10° in and 90° out for bevel work.



**Proper Motor Used**—Only Rockwell offers a heavy duty, 1/2 HP, 3450 RPM motor. You get the right belt speeds for efficient sanding and grinding—4000 SFPM with a standard pulley . . . 4600 SFPM with the contact wheel. Reset button provides overload protection.



**Efficient Rubber Contact Wheel**—A general purpose wheel, it is recommended for a wide variety of jobs including fast removal of stock or rough finishing. Also excellent for flash grinding on soft metals.



**Fully Protected Arbor Shaft**—Arbor shaft bearing is completely enclosed, preventing entry of harmful abrasive dust. Note also the use of husky 3/4" bearing shafts, plus sealed-for-life ball bearing construction throughout.

# ROCKWELL-DELTA 10" Tilting Arbor BENCH SAW

**NOW! For the First Time  
A Bench Saw That Offers...**

- Extra Smooth, Precision Cutting
- Big Saw Performance
- Large Table Capacity
- Easily Operated Controls
- Rugged Construction Throughout

You'll get all these fine features, and more, with the **New Delta 10" Bench Saw.**

Check its big capacities . . . extra large table . . . modern rip fence . . . quick operating controls . . . husky construction . . . and you will agree that it's the **BIGGEST VALUE** in its class.

Let us demonstrate this **new standard** in bench saws for you today!

## MACHINE DATA

Diameter of arbor	5/8"
Diameter of saw blade	10"
Maximum depth of cut	3 1/8"
Maximum rip to right of blade	25"
Maximum rip to right of blade with extra long guide bars (accessory)	50"
Maximum rip to left of blade	15 1/2"
Maximum thickness of cut at 45°	2 1/8"
Distance, front of table to center of blade	16 1/16"
Table in front of blade at maximum cut	12 1/4"
Maximum width of dado	1 3/8"
Table height (bench model)	12 1/4"
Table height (on steel stand)	36 1/8"
Table size	20" x 27"
Table size with extension wings	36" x 27"
Overall dimensions with wings and guide bars	30 1/4" x 45 3/8"
T-Slot miter gage groove in table	3 5/8" x 3/4"
Rip fence locked both front and back by single operating handle at front of machine	
Speed with 3450 rpm motor	4000 rpm
Shipping weight	185 lbs.

ALSO MADE IN CANADA





**EXTRA LARGE TABLE SURFACE** Big 36" x 27" table (with wings) provides extra support for handling large panels. Precision ground table is scientifically ribbed to prevent warping and distortion.



**CONVENIENTLY GROUPED CONTROLS** All controls are grouped "up front" for fast, safe operation. Smooth functioning rack and gear mechanism makes it easy to raise, tilt and lower saw blade while 3-spoke lock holds desired saw settings.



**EXCLUSIVE JET-LOCK RIP FENCE** Single control handle automatically aligns fence parallel to blade as it simultaneously locks to front guide rail, then, fence locks securely to rear guide bar.



**ADJUSTABLE, POSITIVE STOPS ON TABLE** Saw blade stops can be adjusted for perfect 90° and 45° settings on the top of the table. Saw blade insert contains similar adjusting screws for levelling insert in place.



**RUGGED INTERIOR CONSTRUCTION** The heavy trunnions support a large cast iron trunnion bracket which carries the arbor assembly. Note husky rack and gear mechanism that assures smooth, easy positioning of saw blade.



**PREFERRED T-SLOT TABLE** T-slots on either side of saw blade hold miter gage securely, even beyond front of table, providing accurate support for work. Miter gage can't twist or fall out.



**BIG SAW CAPACITIES** This new Delta saw offers capacities not usually found in bench saws — cuts stock 3 1/8" thick . . . rips to center of a 50" panel, 100" with Extra Long Guide Bars (accessory).



**EXCELLENT POWER TRANSMISSION** Observe how motor and V-belt tilt with the saw blade. This means full, even power-transmission to the saw with less wear and strain on the V-belt and motor.

## CATALOG LISTING

**BASIC MACHINE LESS GUARD, SPLITTER AND EXTENSION WINGS:** Includes 10" Tilting Arbor Bench Saw, JET-LOCK rip fence, 1015 combination blade, 34-884 miter gage, front graduated guide bar, rear guide bar, 1451 table insert, 41-203 motor pulley with 5/8" bore and 49-145 V-belt. Without motor and switch. 185 lbs. . . . . **No. 34-400**

### MOTORS AND CONTROLS FOR SINGLE PHASE OPERATION

**Motor, 1 HP, capacitor, 115/230 V, 60 cy, AC, 3450 rpm.** Includes 115 V 8-foot cord with 3-prong grounding type plug but with no control switch. 34 lbs. . . . . **No. 62-731**

**Motor, 1 1/2 HP, capacitor, 115/230 V, 60 cy, AC, 3450 rpm.** Includes 230 V 8-foot cord with 3-prong grounding type plug but with no control switch. 43 lbs. . . . . **No. 62-751**

**Push Button Manual Control Switch and Wiring Kit** for use with 62-731 or 62-751 Motor (also can be used on DC motors). 3 lbs. . . . . **No. 34-891**

### FOR THREE PHASE OPERATION

**Motor, 1 HP, 208-220/440 V, 50/60 Cy, AC, 2850/3450 rpm.** Without switch or power cord. 23 lbs. . . . . **No. 66-731**

**Motor, 1 1/2 HP, 208-220/440 V, 50/60 cy, AC, 2850/3450 rpm.** With out switch or power cord. 34 lbs. . . . . **No. 66-751**

**Switch, Overload.** Used with 34-893 Switch. Easy to mount on steel stand with 49-318 mounting bracket. Specify motor and volt age when ordering. 3 lbs. . . . . **No. 49-365**

**Starter, Magnetic.** For 60 cy, 208-220 V only. Provides low-voltage, no-voltage and overload protection. Used with 34-892 Switch. Easy to mount on steel stand with 49-318 mounting bracket. Specify motor number when ordering. 6 lbs. . . . . **No. 49-396**

**Starter, Magnetic.** For 60 cy, 440 V only. Provides low-voltage, no-voltage and overload protection. Used with 34-892 Switch. Easy to mount on steel stand with 49-318 mounting bracket. Specify motor number when ordering. 6 lbs. . . . . **No. 49-397**

**Push Button Manual Control Switch and Wiring Kit** for use with 66-731 or 66-751 Motor (also can be used with DC motors). 3 1/2 lbs. **No. 34-893**

**Push Button Magnetic Control Switch and Wiring Kit** for use with 66-731 or 66-751 Motor and 49-396 208-220 V Magnetic Starter or 49-397 440 V Magnetic Starter. 3 lbs. . . . . **No. 34-892**

**Mounting Bracket.** Includes screws for mounting 49-365 Overload Switch or 49-396 or 49-397 Magnetic Starters on steel stand. 3 lbs. **No. 49-318**

### ACCESSORIES

**Steel Stand, 24" high with 20 x 2 1/2" top.** 50 lbs. . . . . **No. 50-315**

**Super-Safe Splitter-Mounted Guard.** 8 1/2 lbs. . . . . **No. 34-828**

**Side Extension Wings to make table 36 x 27" (per pair).** 53 lbs. **No. 1455**

**Belt Guard.** 4 lbs. . . . . **No. 34-886**

**Retractable Caster Set.** 13 lbs. . . . . **No. 49-364**

**Extra Long Guide Bars** that permit ripping to center of a 100" panel. 19 lbs. . . . . **No. 34-472**

**Stop Rods for Miter Gage.** 1/2 lb. . . . . **No. 49-302**

**Standard Table Insert.** 1 3/4 lbs. . . . . **No. 1451**

**Dado Head Table Insert.** 1 1/2 lbs. . . . . **No. 1452**

**Moulding Cutterhead Table Insert.** 1 1/2 lbs. . . . . **No. 1453**

**Motor Pulley, 5/8" bore, 3" dia., for 3450 rpm motors.** 2 lbs. **No. 41-203**

**Motor Pulley, 3/4" bore, 3" dia., for 3450 rpm motors.** 2 lbs. **No. 41-204**

**V-belt, 46" O.C., for 62-731, 62-751, 66-731 and 66-751 Motors.** 1/2 lb. . . . . **No. 49-145**

### CONVENIENT ALL-INCLUSIVE NUMBERS FOR SINGLE PHASE OPERATION

**10" Tilting Arbor Bench Saw complete.** Includes 34-400 Saw with 1455 Pair of Side Extension Wings, 50-315 Steel Stand, 34-828 Splitter-Mounted Guard, 62-731 1 HP Motor and 34-891 Manual Control Switch and Wiring Kit. 323 lbs. . . . . **No. 34-401**

### FOR THREE PHASE OPERATION

**10" Tilting Arbor Bench Saw complete.** Includes 34-400 Saw with 1455 Pair of Side Extension Wings, 50-315 Steel Stand, 34-828 Splitter-Mounted Guard, 66-731 1 HP Motor, 34-893 Manual Control Switch and Wiring Kit, 49-365 Overload Switch and 49-318 Mounting Bracket. 329 lbs. . . . . **No. 34-402**

# ROCKWELL-DELTA "PLUS 10" Portable RADIAL SAW

Now with 10" or 12" Blade Guard

A machine that meets the **high standards** required by industry, builders, contractors, commercial and school shops.

**Here's why:**

Extra powerful 1½ HP motor develops up to 3 HP under load to handle the toughest cutting jobs. Rigid frame, massive column base and precision index ring assure top quality cuts on all jobs.

Specially designed trigger switch, fool-proof mechanical brake and all "up-front" operating controls make it the safest radial saw you can buy.

Designed for easy movement, it can be taken right to the job, even carried through a standard entrance, for on-the-spot, centralized cutting.

And, it offers **UNMATCHED VERSATILITY**—you can do every job from conventional sawing to dadoing, moulding, routing and sanding with Delta's more than 100 accessories.

Let us demonstrate this **BIG VALUE** for you today!



Portable Model



Portable Model Shown with Steel Legs for Permanent Installation.

perfect for every user...



Speeds up production on the job for the builder. A BIG CAPACITY saw for industrial users. An extra safe saw for school shops.

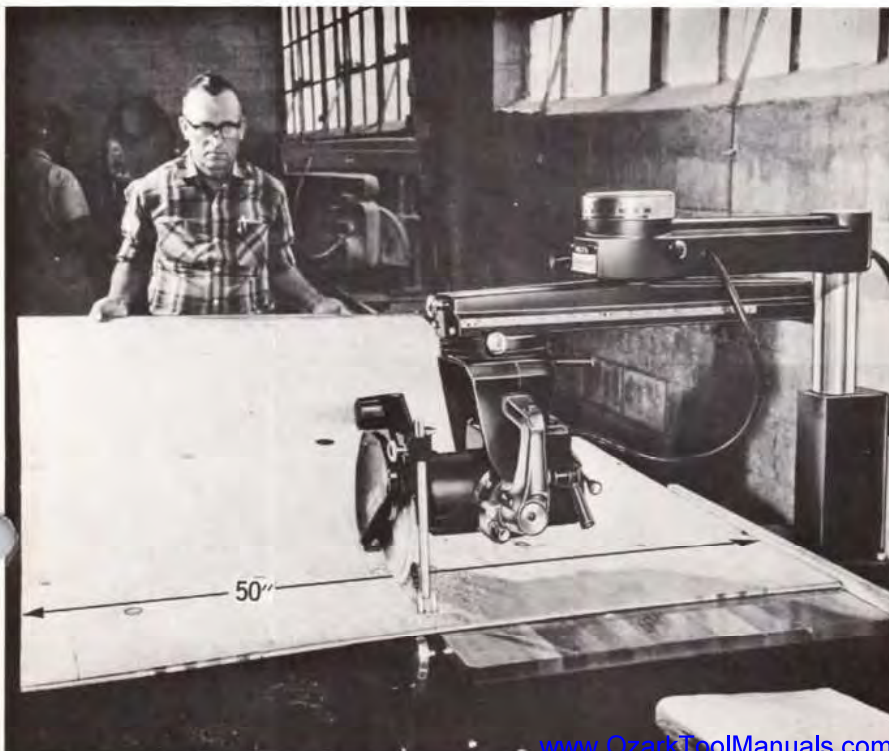

# with all the features you want!

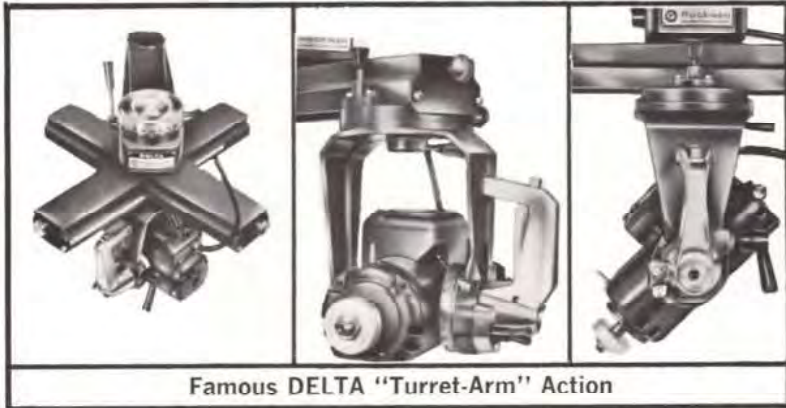

Famous DELTA "Turret-Arm" Action

**SWING IT!** Arm swings 360° in any direction above the table for angle cutting. Features positive stops at 0° and 45°, right and left.

**SPIN IT!** Yoke-motor unit swivels 360° under the arm with positive stops at each 90° position. Makes it easy to rip from either side.

**TILT IT!** Motor tilts inside yoke for beveling, shaping and moulding operations. Gives you a tilting arbor machine with positive stops at 45° and 90°.

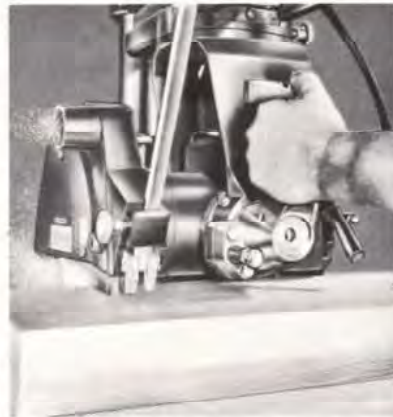

**EXTRA POWERFUL MOTOR.** 1½ HP motor delivers up to 3 HP under heavy work loads to assure faster, smoother cutting. The extra power means extra safety because stalling is virtually eliminated. Threaded right-hand shaft of motor permits use of drill bits, sanding drums and other accessories.



**SAFE ON-OFF SWITCH.** (Single Phase Models Only) Trigger type in design, it is conveniently nestled in the handle with a mechanical linkage to the switch button in the motor junction box. When trigger is released, switch automatically shuts off power. "Red" safety button prevents accidental starting, also locks trigger in "on" position for such operations as ripping.



**FOOL-PROOF MECHANICAL BRAKE.** A dependable, manually operated brake that works every time to assure quick, safe blade stoppage. Brake stops blade almost instantly.

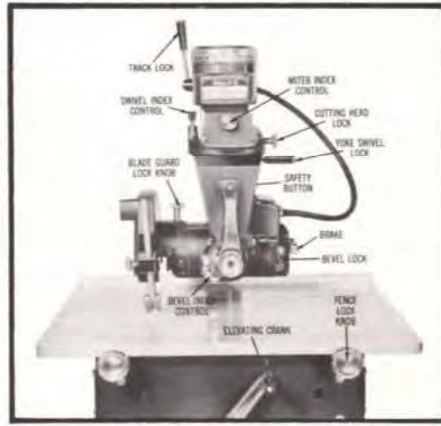

**ALL CONTROLS LOCATED "UP-FRONT."** Every control, including the elevating crank, is "up front," away from the blade for faster, safer operation. Extra long, comfortable hand grips assure greater locking leverage and control.



**PRECISION INDEX RING FOR MITER CUTS.** 90° and 45° positive miter stops are precision machined simultaneously at the factory, assuring lifetime accuracy on the job. Adjustment, if ever required, is easily made. **CONVENIENT INDEX CONTROL.** Index release knob is conveniently located "up front" permitting quick, easy selection of desired miter positions.



**MASSIVE COLUMN AND BASE.** Husky column and rugged base are precision matched. A heavy, built-in, spring-loaded key maintains rigid, accurate alignment of cutting arm yet affords free, easy raising and lowering of cutting head. There are no gibs or wrap-around clamps to get out of adjustment.



**HANDY FENCE LOCK KNOBS.** Large, convenient knobs enable you to adjust and lock the fence from the front for added safety. This important feature saves you time, especially when cutting varying widths of stock.



**LARGE BEVEL AND MITER SCALES.** They are extra large in size and conveniently located, making them easy to use. This speeds up production and improves accuracy on close tolerance jobs.



**HEAVY, DEEP CHANNEL FRAME CONSTRUCTION.** This underside view of the frame shows its rugged, box-type construction that makes it practically distortion proof. This assures continuous alignment of the entire machine, guaranteeing the user trouble-free performance and accuracy year after year.



**BIG CAPACITIES.** Cuts stock up to 3" thick and rips to the center of a 50" panel, with ample table support. In addition, Delta's famous "Turret-Arm" action permits the blade to stay positioned over the table throughout the 360° arm swing. You can even cut left-hand miters and still get full capacity over the table.



**Electrical Controls**—single-phase models are supplied with two-pole trigger type control and integral motor overload switch protection. Three-phase models are supplied with three-pole toggle type manual control with separately mounted thermal overload switch or with magnetic starter with integral control switch. Control and overload switch combination provide on-off control with thermal overload protection. Control switch and magnetic starter combination provide on-off control, low voltage, no voltage and overload protection.

**STANDARD EQUIPMENT**

Extra powerful 1½ or 2 HP motor; manual or magnetic controls; 10" or 12" blade guard with anti-kickback attachment; 10" combination blade; operating and maintenance instructions and wrenches.

**CATALOG LISTING**

H.P.	Voltage	Phase	Cycles	Manual Control w/10" Blade Guard	Magnetic Control w/10" Blade Guard	Manual Control w/12" Blade Guard	Magnetic Control w/12" Blade Guard
1½	115/230	1	60	*33-564		* 33-604	
2	208-220	3	60	* 33-565	* 33-569	* 33-605	* 33-609
2	440	3	60	* 33-566		* 33-606	
2	208	3	60	33-567	* 33-570	33-607	* 33-610
2	550	3	60	33-568		33-608	
Set of four steel legs (for both 10" and 12" models).				50-104			

\*Wired for 230 V operation.  
 • Supplied with 208-220/440 V motor, wired for voltage listed.

**Note: 10 Radial Saws, with motors and controls for power systems not listed, are available upon request.**

**MACHINE DATA**

Motor rating	1½, 2 HP	
Cross cut capacity—1" stock	.16"	
Maximum rip capacity	.25"	
Dado capacity (No. 3 dado)	13/16" wide	
Maximum depth of cut—10" saw	3"	
12" saw	4"	
Diameter of saw arbor	5/8"	
Diameter of combination saw supplied	10"	
Bevel positive stops	0°, 45°, 90°	
Miter positive stops	90° and 45°, R & L	
Type of track	lifetime, wear-resistant iron	
Motor speed (full load) 60 cycles	3450 rpm	
Overall height (on stand)	63½"	
Width of base	21¾"; Depth of base	32"
Wood table top	25½" x 30"	
Height table top (on stand)	33"	
Shipping weight (approx.)—portable model	273 lbs.	

WANT QUALITY PERFORMANCE WITH BIG CAPACITY?

# The **NEW** **ROCKWELL-DELTA** **12" Gap Bed** **WOOD LATHE** **Gives You** **Both!**

## MACHINE DATA

Swing over bed	12"
Swing over bed gap	16" dia. for 2½" stock
Distance between centers	39"
Speeds:	
Variable speed model	600 to 3500 RPM
Four-speed model	915, 1380, 2150, 3260 RPM
Inboard spindle nose	1"—8 RH thread
Outboard spindle nose	1"—8 LH thread
Hole through spindle	⅝"
Headstock and tailstock tapers	No. 2 M.T.
Ram travel	2¼"
Height—centerline of spindle to floor	41¾"
Approx. shipping weight (Floor Models)	345 lbs.
Overall Dimensions:	
Height	45¼"
Width	16½"
Length	60"

*4-Speed Model  
for Wood Turning*

*Variable-Speed Model  
for Wood Turning,  
Metal Spinning,  
Light Metal Turning  
and Plastics*





VARIABLE-SPEED MODEL

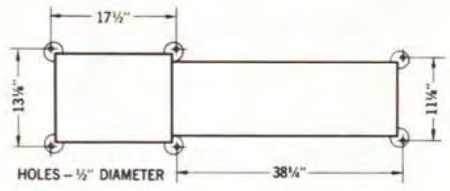

ALSO MADE IN CANADA



4-SPEED MODEL

# Check these Quality Features and see why The **NEW** **ROCKWELL-DELTA** **12" Gap Bed** **WOOD LATHE** **GIVES YOU** **MORE VALUE!**

Its many fine features is only one of the reasons why the New Rockwell-Delta 12" Gap Bed Wood Lathe meets the needs of industry, commercial shops and schools so well.

To appreciate its true value, investigate its **BIG CAPACITY** . . . rugged construction . . . safety of design . . . and its great versatility (more than 50 Rockwell-Delta lathe accessories are available). Then, you will agree that it is the **BIGGEST VALUE** in its class.

Whatever your needs—Variable Speed or 4-Speed—let us "performance-prove" this fine, new Rockwell-Delta Quality Lathe for you today.



**Smooth Operating Variable Speed Drive**—Simply constructed, dual belt drive has few operating parts. Jack shaft, that raises and lowers quickly by means of a rack and pinion, always keeps belts in perfect alignment. This assures higher power transmission efficiency— $\frac{1}{2}$  HP motor does work of  $\frac{3}{4}$  HP motor required with "old-fashioned," spring-loaded drives.

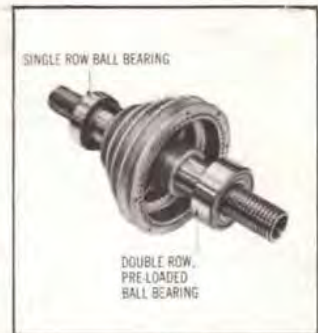

**Rugged Headstock Construction**—Spindle drive is placed between inboard and outboard bearings, reducing spindle whip to a minimum. A double row, pre-loaded, sealed-for-life ball bearing at the inboard end permits maximum thrust for heavy turning and metal spinning . . . "floating" ball bearing construction on outboard end allows for expansion as spindle warms up.



**Modern Tailstock Controls**—Fast operating cam clamp quickly locks massive tailstock to bed. Positive, 360° wrap-around clamp firmly holds ram in position selected. Non-jamming No. 2 M.T. ram automatically ejects centers when retracted. Ram travels a full  $2\frac{1}{8}$ " and is graduated in  $\frac{1}{16}$ ths.



**Convenient Controls**—Variable speed control lever is conveniently placed for quick selection of any speed from 600 to 3500 RPM. When "pushed in," lever locks at desired speed. Adjacent push button switch has a shrouded start button to prevent accidental starts and a protruding stop button for fast emergency stops.



**Famous Indexing Mechanism**—Two rows of holes in headstock pulley—8 and 60—can be engaged quickly by the unique indexing pin. Now, you can obtain the maximum number of index divisions for reeding and fluting.



**Massive Bed**—Made of fine grained cast iron, bed is scientifically ribbed and ruggedly constructed to minimize vibration. Bed and headstock are precision ground for perfect alignment, assuring high quality lathe performance.



**Universal Tool Support**—Exceptionally handy and fast in action. Heavy and substantial, it locks to the bed at any desired position by means of the convenient lever at the front where it does not interfere with the work.

## CATALOG LISTING

### 4-SPEED MODELS

**BASIC MACHINE, WITHOUT CABINET:** Includes 933 spur center, 934 cup center, 1461 tool support base, 692 12" tool support, 46-805 6" tool support, 936 3" face plate and 49-094 V-belt, 81" O.C. Without motor, motor pulley and switch, 135 lbs.....**NO. 46-200**  
**Cabinet,** steel, sturdily constructed, totally encloses motor and drive, has hinged motor plate for easy speed changes, and two shelves, 110 lbs.....**NO. 50-150**  
**Motor Pulley,** 4-step, (specify bore). 2 lbs.....**NO. 932**

COMPLETELY ASSEMBLED MODELS, INCLUDING MOTOR AND CONTROLS, WIRED AND READY TO RUN. SINGLE-PHASE MODELS READY TO BE PLUGGED INTO 115 V OUTLET; THREE-PHASE MODELS WIRED FOR 208-220 V OPERATION. (EACH CAT. NO. SHOWN BELOW IS A COMPLETE MACHINE WITH ELECTRICALS AS LISTED.)

			With Overload Protection
1 Phase, With 62-680 Motor	MANUAL CONTROL	46-211	46-216
		MAGNETIC CONTROL	*
3 Phase, With 66-340 Motor	MANUAL CONTROL	46-213	46-217
		MAGNETIC CONTROL	*

\*Magnetic Control provides overload protection.

### VARIABLE-SPEED MODELS

**BASIC MACHINE, WITH CABINET:** Includes 933 spur center, 934 cup center, 1461 tool support base, 692 12" tool support, 46-805 6" tool support, 936 3" face plate, 49-115 V-belt, 39 $\frac{3}{8}$ " O.C., and 51-008 V-belt, 47 $\frac{1}{8}$ " O.C. Without motor, motor pulley and switch, 305 lbs.....**NO. 46-525**  
**NOTE:** Variable-speed models cannot be furnished without cabinet.  
**Motor Pulley,** (specify bore).  $\frac{3}{4}$  lb.....**NO. 5350**

		With Overload Protection	With Slo-Start Feature	With Overload & Slo-Start
1 Phase, With 62-680 Motor	MANUAL CONTROL	46-526	46-530	46-532
		MAGNETIC CONTROL	*	46-533*
3 Phase, With 66-340 Motor	MANUAL CONTROL	46-528	46-531	46-534
		MAGNETIC CONTROL	*	46-535*

\*Magnetic Control provides overload protection.

### MOTORS AND CONTROLS

#### FOR SINGLE PHASE OPERATION

**Motor,** heavy duty,  $\frac{1}{2}$  HP, 115/230 V, 60 cy, AC, 1725 RPM, with  $\frac{1}{2}$ " shaft, 29 lbs.....**NO. 62-680**  
**Motor,** heavy duty,  $\frac{3}{4}$  HP, 115/230 V, 60 cy, AC, 1725 RPM, with  $\frac{3}{8}$ " shaft, 43 lbs.....**NO. 62-710**

**Motor,** standard duty,  $\frac{1}{2}$  HP, 115/230 V, 60 cy, AC, 1725 RPM, with  $\frac{1}{2}$ " shaft, 20 lbs.....**NO. 62-000**  
**Motor,** standard duty,  $\frac{3}{4}$  HP, 115/230 V, 60 cy, AC, 1725 RPM, with  $\frac{3}{8}$ " shaft, 25 lbs.....**NO. 62-001**  
**Manual Control Push Button Switch Kit,** 1 lb.....**NO. 46-461**  
**Magnetic Control Push Button Switch Kit,** 1 lb.....**NO. 46-462**  
**Overload Switch,** Used with 46-461 Switch Kit, 3 lbs.....**NO. 49-365**  
**Starter,** Magnetic. For 60 cy, 115/230 V. Used with 46-462 Switch Kit, 3 lbs. ....**NO. 49-507**

#### FOR THREE PHASE OPERATION

**Motor,** heavy duty,  $\frac{1}{2}$  HP, 208-220/440 V, 50/60 cy, AC, 1425/1725 RPM, with  $\frac{1}{2}$ " shaft, 25 lbs.....**NO. 66-340**  
**Motor,** heavy duty,  $\frac{3}{4}$  HP, 208-220/440 V, 50/60 cy, AC, 1425/1725 RPM, with  $\frac{3}{8}$ " shaft, 28 lbs.....**NO. 66-710**  
**Motor,** heavy duty,  $\frac{1}{2}$  HP, 208-220/440 V, 50/60 cy, AC, 960/1140 RPM, with  $\frac{1}{2}$ " shaft, 32 lbs.....**NO. 66-342**  
**Motor,** standard duty,  $\frac{1}{2}$  HP, 208-220/440 V, 60 cy, AC, 1725 RPM, with  $\frac{1}{2}$ " shaft, 20 lbs.....**NO. 66-000**  
**Motor,** standard duty,  $\frac{3}{4}$  HP, 208-220/440 V, 60 cy, AC, 1725 RPM, with  $\frac{3}{8}$ " shaft, 25 lbs.....**NO. 66-001**  
**Manual Control Push Button Switch Kit,** 1 lb.....**NO. 46-463**  
**Magnetic Control Push Button Switch Kit,** 1 lb.....**NO. 46-462**  
**Overload Switch,** Used with 46-463 Switch Kit, 3 lbs.....**NO. 49-365**  
**Starter,** Magnetic. For 60 cy, 208-220 V only. Used with 46-462 Switch Kit, 6 lbs. ....**NO. 49-396**  
**Starter,** Magnetic. For 60 cy, 440 V only. Used with 46-462 Switch Kit, 6 lbs. ....**NO. 49-397**

#### SLO-START ACCESSORIES FOR ADDED SAFETY

**Slo-Start Switch Kit** for manual or magnetic control. For use with single phase, three phase and DC motors up to 1 HP, AC-DC, 125-250 V. Kit includes limit switch with operating mechanism, cable, switch cover and lock assembly. When using this switch kit for magnetic control, No. 49-399 or 49-508 Relay is required, 7 lbs.....**NO. 46-460**  
**Relay,** For 60 cy, 115 V only. Used with 46-460 Switch Kit and 49-507 Starter for single phase operation, 2 lbs...**NO. 49-508**  
**Relay,** For 60 cy, 208-220 V only. Used with 46-460 Switch Kit and 49-396 Starter for three phase operation, 2 lbs.....**NO. 49-399**

## Make Lathe Operations Safer with DELTA'S Slo-Start Feature!



This accessory provides maximum safety for novice lathe operators in schools, training institutions, etc. With it the lathe can be started *only* at the slowest speed. Above, the shop instructor locks hood after pressing switch button to "on" position, ready for student's use.



Now, student starts lathe by merely pulling variable speed control lever to right. When desired speed is obtained, he pushes lever in, locking it in position. Then, he proceeds to operate the lathe.



Should a danger signal suddenly appear, the operator's first reaction would be to stop the lathe. This he does by pressing the "stop" button. Then, the difficulty is determined, either by the student or the instructor, and corrected.



Now, the lathe cannot be started again by actuating the variable speed control lever since the current is off. The locked hood also makes the "start" button inaccessible. Therefore, the instructor must unlock the hood, press the "start" button and lock the hood again before the student can proceed.



# Rockwell

MANUFACTURING COMPANY

The Rockwell Building • Pittsburgh, Pa. 15208